

BAB V PENUTUP

V.1 Kesimpulan

Berdasarkan hasil penelitian yang sudah dilakukan, sehingga dapat diambil kesimpulan sebagai berikut:

1. Alat uji kinerja motor dan *propeller drone* ini dirancang berdasarkan metodologi VDI 2206 dan telah memenuhi daftar tuntutan sebagai berikut:

Tabel V.1 Verifikasi Daftar Tuntutan

No	Daftar Tuntutan	Kuantifikasi	Hasil Rancangan	Keterangan
<i>Demand</i>				
1	Rentang ukuran diameter <i>propeller</i> yang bisa diuji.	∅ 2 inci – ∅15 inci	Tinggi Alat 440 mm	Terpenuhi
2	Rentang ukuran diameter motor yang bisa diuji.	∅ 10 mm – ∅ 147,5 mm	∅ 10 mm – ∅ 147,5 mm (Lampiran 6 – DTS-06)	Terpenuhi
3	Defleksi maksimum alat uji.	< 0,5 mm	0,304 mm	Terpenuhi
4	Rentang kemampuan menahan gaya dorong.	24,5 N – 981 N	981 N	Terpenuhi
5	Biaya relatif murah dalam perancangan alat uji, pengadaan material, dan proses manufaktur.	< Rp. 17.000.000	Rp. 5.183.860 (Lampiran 5.21)	Terpenuhi
<i>Wish</i>				
6	Mudah digunakan.	<10 langkah pengujian.	6 langkah	Terpenuhi

7	Kemampuan mengolah data yang baik.	Mampu menampilkan data secara <i>real-time</i> selama pengujian.	<i>Human Machine Interface</i>	Terpenuhi
8	Dapat menyimpan data hasil uji.	Data dapat diekspor dalam format standar yang dapat diakses.	Format CSV	Terpenuhi

2. Seluruh komponen yang berpotensi mengalami titik kritis telah dihitung dan disimulasikan, dan hasilnya menunjukkan bahwa semua komponen tersebut memenuhi syarat keamanan, sehingga konstruksi dinyatakan aman.
3. Gambar kerja dari alat uji kinerja motor dan *propeller drone* dapat dilihat pada lampiran 6.
4. Alat uji yang telah diintegrasikan memiliki fungsionalitas yang baik. Pengujian kali ini difokuskan pada pengukuran gaya dorong (*thrust*).

V.2 Saran

Berdasarkan hasil penelitian yang telah dilakukan, beberapa saran untuk pengembangan di masa mendatang adalah sebagai berikut.

1. Untuk meningkatkan keselamatan operator, perlu dirancang dan diimplementasikan penutup atau pelindung guna mencegah kontak langsung dengan putaran *propeller* yang berpotensi membahayakan.
2. Diperlukan pengembangan lebih lanjut pada domain elektronika dan domain informatika untuk memastikan validitas dan akurasi data pengukuran yang dihasilkan.

DAFTAR PUSTAKA

- [1] H. Shakhathreh *et al.*, “Unmanned Aerial Vehicles: A Survey on Civil Applications and Key Research Challenges,” *IEEE Access*, vol. 7, pp. 48572–48634, 2019, doi: 10.1109/ACCESS.2019.2909530.
- [2] G. Szafranski, R. Czyba, and M. Blachuta, “Modeling and identification of electric propulsion system for multirotor unmanned aerial vehicle design,” in *2014 International Conference on Unmanned Aircraft Systems (ICUAS)*, Orlando, FL, USA: IEEE, May 2014, pp. 470–476. doi: 10.1109/ICUAS.2014.6842287.
- [3] H. R. Mas Intan, Muhammad Luqman Bukhori, and Sabri Alimi, “RANCANG BANGUN ALAT UJI THRUST MOTOR BRUSHLESS DENGAN VARIASI PROPELLER,” *teknika*, vol. 9, no. 1, pp. 65–75, July 2023, doi: 10.56521/teknika.v9i1.836.
- [4] M. Podsędkowski, R. Konopiński, D. Obidowski, and K. Koter, “Variable Pitch Propeller for UAV-Experimental Tests,” *Energies*, vol. 13, no. 20, p. 5264, Oct. 2020, doi: 10.3390/en13205264.
- [5] I. Putra Nurhakim, G. Marausna, and F. Jayadi, “ANALISIS PERFORMA PROPELLER UNTUK CARGO DRONE DENGAN VARIASI AIRFOIL MENGGUNAKAN METODE EKSPERIMEN,” *teknika*, vol. 8, no. 2, pp. 295–301, Nov. 2022, doi: 10.56521/teknika.v8i2.647.
- [6] L. Pramesti, R. D. E. Witjonarko, and B. B. A. Aji, “Analisis Performa Propeller Kaplan 4-55 dengan Pendekatan Computational Fluid Dynamic (CFD),” *G-Tech*, vol. 6, no. 2, pp. 249–256, Sept. 2022, doi: 10.33379/gtech.v6i2.1692.
- [7] J. C. R. Sihaan, A. Munawir, and Z. Husin, “ANALISIS GAYA DORONG (THRUST) PROPELLER PADA PESAWAT MODEL REMOTE CONTROL (UAV),” *JMKN*, vol. 8, no. 1, p. 135, June 2022, doi: 10.35308/jmkn.v8i1.5698.
- [8] Yamish Singh, Rajanarasimha Sangam, and Abhijeet Karmarkar, “Assembly and Programming of Hexacopter Drone for Surveillance and Medical Kit Delivery Purposes,” *Int Res J Adv Engg Hub*, vol. 2, no. 06, pp. 1794–1803, June 2024, doi: 10.47392/IRJAEH.2024.0246.

- [9] admin, “Drone Multirotor VS Drone Fixed Wing,” Terra Drone Store. Accessed: Nov. 16, 2024. [Online]. Available: <https://store.terra-drone.co.id/drone-multirotor-vs-drone-fixed-wing/>
- [10] F.-P. Thamm, N. Brieger, K.-P. Neitzke, M. Meyer, R. Jansen, and M. Mönninghof, “SONGBIRD – AN INNOVATIVE UAS COMBINING THE ADVANTAGES OF FIXED WING AND MULTI ROTOR UAS,” *Int. Arch. Photogramm. Remote Sens. Spatial Inf. Sci.*, vol. XL-1/W4, pp. 345–349, Aug. 2015, doi: 10.5194/isprsarchives-XL-1-W4-345-2015.
- [11] “Drone VTOL: Segala Hal yang Perlu Anda Ketahui-T-DRONES.” Accessed: Nov. 16, 2024. [Online]. Available: <https://www.t-drones.com/blog/VTOL-drone-guide.html>
- [12] S. Agostino, M. Mammone, M. Nelson, and T. Zhou, “CLASSIFICATION OF UNMANNED AERIAL VEHICLES”.
- [13] “Untuk Angkatan Udara AS, drone Global Hawk senilai \$ 130 juta RQ-4 sudah usang.” Accessed: Feb. 16, 2025. [Online]. Available: <https://meta-defense.fr/id/2021/05/10/untuk-angkatan-udara-drone-a-130-m-rq-4-global-hawk-sudah-usang/>
- [14] “Army Dumps All-Seeing Chopper Drone | WIRED.” Accessed: Feb. 16, 2025. [Online]. Available: <https://www.wired.com/2012/06/hummingbird/>
- [15] “RQ-11B Raven,” Air Force. Accessed: Feb. 16, 2025. [Online]. Available: <https://www.af.mil/About-Us/Fact-Sheets/Display/Article/104533/rq-11b-raven/https%3A%2F%2Fwww.af.mil%2FAbout-Us%2FFact-Sheets%2FDisplay%2FArticle%2F104533%2Frq-11b-raven%2F>
- [16] “DJI Flycart 30,” Halo Robotics. Accessed: Feb. 16, 2025. [Online]. Available: <https://halorobotics.com/shop/drones/dji-flycart-30/>
- [17] “UAV & Drone Propellers | Manufacturers of Drone Blades & Rotors,” Unmanned Systems Technology. Accessed: Nov. 16, 2024. [Online]. Available: <https://www.unmannedsystemstechnology.com/expo/uav-drone-propellers/>

- [18] D. N. Yunita and A. Winarno, “ANALISA TEKNIS PENGARUH JUMLAH SUDU PROPELLER BEBAS PUTAR TERHADAP GAYA DORONG KAPAL TUNDA DPS IX,” 2019.
- [19] H. Sahin and T. Oktay, “POWERPLANT SYSTEM DESIGN FOR UNMANNED TRICOPTER,” *Engineering and Science*, 2017.
- [20] E. E. Prasetyo and Wahyuni Fajar Arum, “Analisis Perbandingan Kinerja Brushless Motor Menggunakan Metode Eksperimen,” *JNTETI*, vol. 10, no. 1, pp. 71–76, Feb. 2021, doi: 10.22146/jnteti.v10i1.987.
- [21] “Electronic Speed Controller (ESC) for Drones and UAVs,” JOUAV. Accessed: July 15, 2025. [Online]. Available: <https://www.jouav.com/blog/electronic-speed-controller-esc.html>
- [22] S. Nurachmandani, *Fisika 1: Untuk SMA/ MA Kelas X*. Jakarta: Pusat Perbukuan Departemen Pendidikan Nasional, 2009.
- [23] A. Wibowo, “Teknologi Drone.” Yayasan Prima Agus Teknik, 2022.
- [24] S. Physics, “The Physics of Drones: Understanding How They Fly,” StickMan Physics. Accessed: July 17, 2025. [Online]. Available: <https://stickmanphysics.com/physics-of-drones/>
- [25] T. Robotics, “Drone Design - Calculations and Assumptions,” Tyto Robotics. Accessed: Nov. 14, 2024. [Online]. Available: <https://www.tytorobotics.com/blogs/articles/the-drone-design-loop-for-brushless-motors-and-propellers>
- [26] “Kekuatan Bilah Turbin Angin - Teknologi Kincir Angin.” Accessed: May 24, 2025. [Online]. Available: <https://windmillstech.com/wind-turbine-blade-forces/>
- [27] N. H. Abdullah, T. F. Wahida Ku Chik, F. A. Zaraini, and A. Ammar, “Load Cell Application in Rocket Thrust Measurement System,” *AMM*, vol. 225, pp. 437–441, Nov. 2012, doi: 10.4028/www.scientific.net/AMM.225.437.
- [28] T. Robotics, “Series 1585 Thrust Stand Bundle,” Tyto Robotics. Accessed: Nov. 18, 2024. [Online]. Available: <https://www.tytorobotics.com/products/series-1580-test-stand-bundle>
- [29] A. Kolaei, D. Barcelos, and G. Bramesfeld, “Experimental Analysis of a Small-Scale Rotor at Various Inflow Angles,” *International Journal of*

- Aerospace Engineering*, vol. 2018, pp. 1–14, Oct. 2018, doi: 10.1155/2018/2560370.
- [30] S. Aminah, A. S. Sunarya, and N. Hadiatiningsih, “Perancangan Sistem Peminjaman Alat Praktikum Pada Laboratorium dengan Metode VDI 2206,” 2019.
- [31] M. A. Royandi and I. A. Effendi, “PERANCANGAN SISTEM TRANSMISI SPINDEL MESIN BUBUT PMS- PICCO 450 MENGGUNAKAN MEKANISME CONTINUOUSLY VARIABLE TRANSMISSION DENGAN PENDEKATAN METODE RETROFIT”.
- [32] Y. F. Giantoyo, “Pengembangan Alat Peraga Kekuatan Material di Kampus Polman Bandung Menggunakan Metode VDI 2206.” Tugas Akhir, Program Studi Rekayasa Perancangan Mekanik Jurusan Teknik Perancangan Manufaktur, Politeknik Manufaktur Bandung, 2024.
- [33] “Nano | Dokumentasi Arduino.” Accessed: July 16, 2025. [Online]. Available: <https://docs.arduino.cc/hardware/nano/>
- [34] “Karakteristik Sensor Arus ACS 712,” Andalan Elektro. Accessed: July 16, 2025. [Online]. Available: <https://www.andalanelektro.id/2018/11/karakteristik-sensor-suhu-ac-712.html>
- [35] D. Abrar Sulthani, “Konsep Perancangan dan Penyusunan Proposal Penelitian,” *dikdaya*, vol. 13, no. 1, p. 68, Apr. 2023, doi: 10.33087/dikdaya.v13i1.394.
- [36] “en.1999.1.1.2007.”
- [37] R. C. Hibbeler, *Mechanics of materials*, Tenth edition. Boston: Pearson, 2017.
- [38] “ASM Material Data Sheet.” Accessed: June 03, 2025. [Online]. Available: <https://asm.matweb.com/search/specificmaterial.asp?bassnum=ma6061o>
- [39] “8080 / 80120 / 80160 / 8840 , Slot Width 8mm Aluminum Frames | MISUMI,” MISUMI Indonesia. Accessed: June 03, 2025. [Online]. Available: https://id.misumi-ec.com/vona2/detail/110310152999/?lisid=lisid_economy_0724&gad_source=1&gad_campaignid=21515815407&gbraid=0AAAAApeiHasfEmEZO1eP

_jenQZcGuRu2M&gclid=EAIaIQobChMI7vqyp-
KOjQMVuWqDax3ujwiQEAAAYASAAEgK5uPD_BwE

- [40] H. Wittel, D. Jannasch, J. Voßiek, and C. Spura, *Roloff/Matek Maschinenelemente: Normung, Berechnung, Gestaltung*. Wiesbaden: Springer Fachmedien Wiesbaden, 2019. doi: 10.1007/978-3-658-26280-8.

Lampiran 1
(Data Diri)



RAFI YOGA PRATAMA

+62 899-6977-038 | rafiyoqa123@gmail.com |

Kp. Pasir Kaliki Barat No.21 RT 05 RW 15, Kel Sadang Serang, Kec Coblong, Kota Bandung, Jawa Barat 40133

TENTANG SAYA

Saya merupakan mahasiswa semester akhir di jurusan Teknik Perancangan Manufaktur, Politeknik Manufaktur Negeri Bandung yang memiliki semangat dan rasa keingintahuan dalam bidang manufaktur. Saya seorang yang bertanggung jawab, disiplin serta mampu berkerja secara individu maupun dalam tim.

RIWAYAT PENDIDIKAN

Politeknik Manufaktur Negeri Bandung <ul style="list-style-type: none">Jurusan Teknik Perancangan Manufaktur	Bandung, Jawa Barat September 2021 - Sekarang
SMK Negeri 12 Kota Bandung <ul style="list-style-type: none">Jurusan Pemesinan Pesawat Udara	Bandung, Jawa Barat Juni 2018 - Juni 2021

RIWAYAT ORGANISASI

Badan Eksekutif Mahasiswa - Keluarga Mahasiswa (BEM-KM) Polman Bandung <ul style="list-style-type: none">Menteri KOMINFOStaf Muda Media Kreatif Kementerian KOMINFO	April 2023 - April 2024 April 2022 - April 2023
Himpunan Mahasiswa Teknik Perancangan (HMTP) Polman Bandung <ul style="list-style-type: none">Anggota Departemen Kaderisasi	Juni 2023 - Juni 2024
Unit Kegiatan Mahasiswa Karsa Marintara (Drone) <ul style="list-style-type: none">Wakil Ketua UKM	Februari 2023 - Januari 2024
Unit Kegiatan Mahasiswa Otomotif <ul style="list-style-type: none">Anggota Divisi <i>Content & Media</i>	Juli 2021 - Februari 2023
Pramuka Satuan Karya Dirgantara Lanud Husein Sastranegara Kota Bandung <ul style="list-style-type: none">Anggota Divisi <i>Airpedia</i>Anggota Divisi Dirgantara <i>Rescue</i>Anggota Krida Olahraga Dirgantara	Mei 2023 - Januari 2024 Mei 2021 - Mei 2023 Mei 2019 - Mei 2021

PENGALAMAN KEGIATAN

PT. Sanggar Sarana Baja - Tangerang <ul style="list-style-type: none"><i>Intern</i> - Departemen <i>Production Engineering - Team Welding</i>	Januari 2024 - Juni 2024
Open House and Campus Expo 2023 Polman Bandung <ul style="list-style-type: none">Ketua Divisi Publikasi, Dokumentasi dan Dekorasi (PDD)	November 2023
Pengenalan Mesin dan Perawatan Pesawat Udara IV <ul style="list-style-type: none">Anggota Divisi <i>Design Graphic</i>	Oktober 2023
Masa Pengenalan dan Pembekalan Perkuliahan (MP3) 2023 <ul style="list-style-type: none">Wakil Ketua Divisi Publikasi, Dokumentasi dan Dekorasi (PDD)	Juli 2023
Masa Pengembangan Karakter Mahasiswa Perancangan (MPKMP) 2023 <ul style="list-style-type: none">Pengawas Kegiatan	Juli 2023
TED X Dago 2023 <ul style="list-style-type: none">Divisi <i>Procurement</i>	Juli 2023
Pengenalan Mesin dan Perawatan Pesawat Udara III <ul style="list-style-type: none">Divisi Keamanan	Oktober 2022

SKILLS

Software

Autocad | Creo/ Pro Engineer | Solidwork | Adobe Photoshop | Ms. Office

Hardskills

Milling | Turning | Drilling

Softskills

Kepemimpinan | Kerjasama | Berfikir Kritis

LAMPIRAN 2
(Data Penelitian)

Lampiran 2.1 Data Merk Motor Drone

T-Motor																				
No	Merek Motor	Series	Ukuran Motor	KV Rating	No	Merek Motor	Series	Ukuran Motor	KV Rating	No	Merek Motor	Series	Ukuran Motor	KV Rating						
1	T-Motor	U3	41,8 x 30,75 mm	700	47	T-Motor					T-Motor	V10L	106,6 x 53 mm	170						
2		U5	42,5 x 37,5 mm	400	48							AT2820	35,2 x 63,5 mm	880	93	V13L	144,2 x 78,1 mm	65		
3		U7 V2	60,7 x 39,5 mm	280	49							AT2826	35,2 x 69,5 mm	1050	94	AM20	25,4 x 15 mm	1500		
4				420	50									1250	95			1900		
5				490	51									900	96			1450		
6				1100	97									550	98			1750		
7		U11II	79,5 x 51,6 mm	120	52							AT3520	43 x 65 mm	720	99	AM30	29 x 16,6 mm	2280		
8		U13 II	100 x 60 mm	130	53									850	100			1500		
9		U15 II	147,5 x 55 mm	80	55									AT3530	43 x 75 mm			250	102	AM40 3D/4D
10				100	56							500	103			1550				
11		U8 Lite	87,1 x 28,05 mm	85	57							AT4120	50 x 69 mm	560	104	AM40V2	28 x 18,7 mm	1880		
12				100	58									250	105			2560		
13				150	59									540	106			AM83	29 x 28,5 mm	600
14				190	60									230	107					650
15		U8 Lite L	87,1 x 28,05 mm	95	61							AT4125	50 x 74 mm	300	108	AM480	49 x 70 mm	900		
16				110	62									450	109			525		
17		U8 II	87,1 x 29,1 mm	85	63							AT4130	50 x 79 mm	220	110	AM600	63,5 x 96 mm	555		
18				100	64									380	111			480		
19				150	65									220	112			520		
20				190	66									380	113			1550		
21		U8 II Lite	87,3 x 26,05 mm	85	67							AT5220A	60 x 112,3 mm	200	114	AM60 V2	28 x 22,1 mm	2200		
22				100	68							AT5220B	60 x 120 mm	200	115			1500		
23		U8 II Pro	87,3 x 29,55 mm	100	69							AT5230A	60 x 122,3 mm	200	116	AS2303	28 x 16,5 mm	1800		
24		U10 II	98,6 x 33,1 mm	100	70							AT5230B	60 x 130 mm	200	117			2300		
25		U12 II	106,8 x 47,6 mm	60	71							AT5330A	63 x 117,3 mm	220	118	AS2304	28 x 16,5 mm	1500		
26				120	72							200	119	2300						
27		P60 Pin	69 x 37 mm	170	73							AT7125	81,4 x 57,9 mm	220	118	AS2306	28 x 19 mm	1900		
28				340	74									245	119			2300		
29		P60 Without Pin	69 x 37 mm	170	75							AT7224	81,4 x 66,9 mm	160	121	AS2308	29,4 x 40,5 mm	1500		
30				340	76									190	122			2300		
31		P80 III Pin	91,6 x 43 mm	100	77							AT8020	90 x 70,8 mm	180	123	AS2312	29,4 x 44,5 mm	1400		
32				120	78									210	124			880		
33		P80 III Without Pir	91,6 x 43 mm	100	79							AT8025	90 x 75,8 mm	160	125	AS2317	29,4 x 52 mm	1250		
34				120	80									190	126			900		
35		AT2308	28,8 x 40,5 mm	1450	81							AT8030	90 x 80,8 mm	160	127	AS2814	36,2 x 54,5 mm	1050		
36				2600	82									190	128			1200		
37		AT2312	28,8 x 44,5 mm	1150	83							AT1030	100 x 99,8 mm	90	129	AS2820	36,2 x 62,2 mm	1050		
38				1400	84							90	130	880						
39		AT2317	28,8 x 52 mm	880	85							AT1040	110,6 x 109,8 mm	90	131	AS2814	36,2 x 54,5 mm	1200		
40				1250	86							AT1050	110,6 x 119,8 mm	90	132			2000		
41		AT2321	28,8 x 56 mm	1400	87							AX335B	39 x 76,5 mm	425	133	AS2814	36,2 x 54,5 mm	1050		
42				950	88							V505	55,6 x 38,9 mm	260	134			1200		
43		AT2814	35,2 x 54,4 mm	1250	89							V602	68,8 x 36,9 mm	180	135	AS2814	36,2 x 54,5 mm	1200		
44				900	90							V605	68,8 x 39,9 mm	210	136			880		
45		AT2814	35,2 x 54,4 mm	1050	91							V804	88,5 x 43,4 mm	170	136	AS2820	36,2 x 62,2 mm	1050		
46				1200	92							V807	88,5 x 46,4 mm	170	137			1250		
						V810	106,6 x 48 mm	160												

SunnySky						Hobbywing								
No	Merek Motor	Series	Ukuran Motor	KV Rating	No	Merek Motor	Series	Ukuran Motor	KV Rating	No	Merek Motor	Series	Ukuran Motor	KV Rating
1	SunnySky	A2212	27,5 x 40 mm	960	55	SunnySky	V4006	43,6 x 18 mm	320	1	Hobbywing	V9626	104,5 x 64,2 mm	160
2				1400	56				380	2		V8114	87,7 x 42,7 mm	160
3				2450	57				740	3		V8120	87,7 x 47,9 mm	160
4			A2216	27,7 x 34 mm	880			58	380	4		V8014	89,1 x 47,45 mm	170
5					1250			59	600	5		V8017	89,1 x 50,45 mm	160
6					2400			60	330	6		V6212	68,7 x 39,3 mm	180
7			R2207	27,4 x 20,5 mm	1800			61	400	7		V6215	68,7 x 39,3 mm	210
8					2580			62	340	8		V5212	58 x 37,2 mm	275
9			R2206	27,4 x 31,5 mm	2300			63	300	9		M13842	150,2 x 89,5 mm	34
10					2500			64	1480	10			38	
11			R2304	28 x 19,3 mm	1480			65	1800	11		M8108	87,1 x 26,9 mm	85
12					1800			66	1500	12			100	
13		X2302	28 x 20,6 mm	1500	67		1900	13	M8110	87,1 x 28,9 mm		95		
14				1650	68		1100	14		110				
15		X2304	28 x 22,2 mm	1400	69		1260	15	M8108 UL	87,1 x 25,4 mm		85		
16				1480	70		1500	16				100		
17				1800	71		2600	17	150					
18		X2305	28 x 23,6 mm	1450	72		980	18	M8110 UL	87,1 x 27,4 mm		95		
19				1620	73		1250	19				110		
20				1850	74		1400	20	M6210	68,7 x 30,2 mm		170		
21		X2204	27 x 21,1 mm	1480	75		2450	21		320				
22				1800	76		880	22	M2615	68,7 x 35,2 mm		160		
23		X2206	27 x 23,3 mm	1500	77		1100	23		320				
24				1900	78		1250	24	M6208	68,7 x 25,8 mm		155		
25		M8	86,8 x 23,9 mm	100	79		1400	25		310				
26				135	80		1800	26	M5208	58 x 29,8 mm		320		
27				170	81		2400	27		380				
28				200	82		880	28	M508 UL	58 x 29,7 mm		340		
29				100	83		1100	29				360		
30				M8 Pro	86,8 x 23,9 mm		135	84	1250	30		M4006	44,4 x 19,7 mm	330
31		170	85				1400	31		350				
32		200	86				1800							
33		V2216	28 x 32 mm	800	87		2400							
34				900	88		900							
35		V2814	35 x 34 mm	700	89		900							
36		X2212 New	27,5 x 42 mm	980	90		1000							
37		R0705	10 x 11,5 mm	15000	91		1250							
38		R1102	14,2 x 9,6 mm	8000	92		800							
39		R1104	14,2 x 11,6 mm	5500	93		920							
40				7500	94		1100							
41		R1106	14,2 x 13,6 mm	5500	95		880							
42				6500	96		520							
43				8000	97		720							
44		R2204	27,4 x 16,5 mm	2300	98		880							
45		R2205	27,4 x 18 mm	2300	99		520							
46		V2806	35 x 18 mm	400	100		720							
47				650	101		880							
48		V3506	41,8 x 18 mm	400	102		210							
49				650	103		250							
50		V3508	41,8 x 20 mm	350	104		370							
51				580	105		200							
52				700			235							
53		V4004	43,6 x 16 mm	300										
54				400										

Hobbywing					
No	Merek Motor	Series	Ukuran Motor	KV Rating	
1	Hobbywing	V9626	104,5 x 64,2 mm	160	
2		V8114	87,7 x 42,7 mm	160	
3		V8120	87,7 x 47,9 mm	160	
4		V8014	89,1 x 47,45 mm	170	
5		V8017	89,1 x 50,45 mm	160	
6		V6212	68,7 x 39,3 mm	180	
7		V6215	68,7 x 39,3 mm	210	
8		V5212	58 x 37,2 mm	275	
9		M13842		150,2 x 89,5 mm	34
10					38
11		M8108		87,1 x 26,9 mm	85
12					100
13		M8110		87,1 x 28,9 mm	95
14					110
15		M8108 UL		87,1 x 25,4 mm	85
16					100
17					150
18		M8110 UL		87,1 x 27,4 mm	95
19					110
20		M6210		68,7 x 30,2 mm	170
21					320
22		M2615		68,7 x 35,2 mm	160
23					320
24		M6208		68,7 x 25,8 mm	155
25					310
26		M5208		58 x 29,8 mm	320
27					380
28		M508 UL		58 x 29,7 mm	340
29					380
30		M4006		44,4 x 19,7 mm	330
31		M4006 UL		44,4 x 19,3 mm	350

Lampiran 3
(Penilaian Konsep)

Lampiran 3.1 Rubrik Penilaian Domain Mekanik

Rubrik Penilaian Domain Mekanik						
Aspek Teknis						
No	Aspek Penilaian	0	1	2	3	4
1	Pencapaian Fungsi	Sama sekali tidak memenuhi tuntutan fungsi (0%).	Hanya memenuhi tuntutan fungsi sebesar 1 – 25%.	Dapat memenuhi tuntutan fungsi sebesar 26 – 50%.	Dapat memenuhi tuntutan fungsi sebesar 51 – 75%.	Dapat memenuhi tuntutan fungsi sebesar 76 – 100%.
2	Konstruksi	Konstruksi tidak mampu menahan beban (0 Kg).	Konstruksi mampu menahan beban < 25 Kg.	Konstruksi mampu menahan beban 25 – 50 Kg.	Konstruksi mampu menahan beban 51 – 75 Kg.	Konstruksi mampu menahan beban 76 – 100 Kg.
3	Pembuatan	> 50% Komponen sulit dibuat/ proses.	40 - 50% Komponen sulit dibuat/ proses.	30 - 40% Komponen sulit dibuat/ proses.	20 - 30% Komponen sulit dibuat/ proses.	< 20% Komponen sulit dibuat/ proses.
4	Perakitan	Memerlukan > 5 jenis alat bantu.	Memerlukan 4 - 5 jenis alat bantu.	Memerlukan 3 - 4 jenis alat bantu.	Memerlukan 2 - 3 jenis alat bantu.	Memerlukan < 2 jenis alat bantu.
5	Pengoperasian	Memerlukan > 10 langkah pengoperasian.	Memerlukan 8 - 10 langkah pengoperasian.	Memerlukan 6 - 7 langkah pengoperasian.	Memerlukan 3 - 5 langkah pengoperasian.	Memerlukan < 3 langkah pengoperasian.

Aspek Ekonomis						
No	Aspek Penilaian	0	1	2	3	4
1	Biaya Pembuatan	Perkiraan biaya pembuatan > Rp. 10.000.000.	Perkiraan biaya pembuatan Rp. 8.000.000 – Rp. 10.000.000.	Perkiraan biaya pembuatan Rp. 6.000.000 – Rp. 7.000.000.	Perkiraan biaya pembuatan Rp. 3.000.000 – Rp. 5.000.000.	Perkiraan biaya pembuatan < Rp. 3.000.000.
2	Biaya Perawatan	90–100% komponen perlu diganti berkala.	80-89% komponen perlu diganti berkala.	60-79% komponen perlu diganti berkala.	40-59% komponen perlu diganti berkala.	20-49% komponen perlu diganti berkala.
3	Penggunaan Komponen Standar	<30% komponen menggunakan komponen standar.	30-40% komponen menggunakan komponen standar.	40-60% komponen menggunakan komponen standar.	70-80% komponen menggunakan komponen standar.	80-100% komponen menggunakan komponen standar.

Lampiran 4
(Perhitungan Kontruksi)

Lampiran 4.1 Material *Properties* Aluminium 6061 [38]

Mechanical Properties			
Hardness, Brinell	30	30	AA; Typical; 500 g load; 10 mm ball
Ultimate Tensile Strength	124 MPa	18000 psi	AA; Typical
Tensile Yield Strength	55.2 MPa	8000 psi	AA; Typical
Elongation at Break	25 %	25 %	AA; Typical; 1/16 in. (1.6 mm) Thickness
Elongation at Break	30 %	30 %	AA; Typical; 1/2 in. (12.7 mm) Diameter
Modulus of Elasticity	68.9 GPa	10000 ksi	AA; Typical; Average of tension and compression. Compression modulus is about 2% greater than tensile modulus.
Ultimate Bearing Strength	228 MPa	33100 psi	Edge distance/pin diameter = 2.0
Bearing Yield Strength	103 MPa	14900 psi	Edge distance/pin diameter = 2.0
Poisson's Ratio	0.33	0.33	Estimated from trends in similar Al alloys.
Fatigue Strength	62.1 MPa	9000 psi	AA; 500,000,000 cycles completely reversed stress; RR Moore machine/specimen
Machinability	30 %	30 %	0-100 Scale of Aluminum Alloys
Shear Modulus	26 GPa	3770 ksi	Estimated from similar Al alloys.
Shear Strength	82.7 MPa	12000 psi	AA; Typical

Lampiran 4.2 Momen Inersia Rangka [39]

Type	Profile	Overall Length L	Profile Type	Mass kg/m	Cross Sectional Moment of inertia	
					Ix (cm ⁴)	Iy (cm ⁴)
LCF8	8080	50 ~ 2000(2500)	Standard	4.83	134.08	134.08
LCFW8			Heavy Duty	6.3	171.2	171.2
LCFX8	8080		Bevel	4.95	72.97	72.97
LCFZ8	8840		Right Angled	3.81	85.03	85.03
LCF	8840		Curved	3.33	116.72	116.72
LCF8	80120		Standard	7.87	501.7	243.73
LCF8	80160		Standard	8.81	1100.71	325.77

Lampiran 4.3 Material *Properties* SS400

Property	Value	Units
Elastic Modulus	2.100000031e+11	N/m ²
Poisson's Ratio	0.28	N/A
Shear Modulus	7.9e+10	N/m ²
Mass Density	7800	kg/m ³
Tensile Strength	360000000	N/m ²
Compressive Strength		N/m ²
Yield Strength	235000000	N/m ²
Thermal Expansion Coefficient	1.1e-05	/K
Thermal Conductivity	14	W/(m·K)

Lampiran 4.4 Momen Inersia Bracket

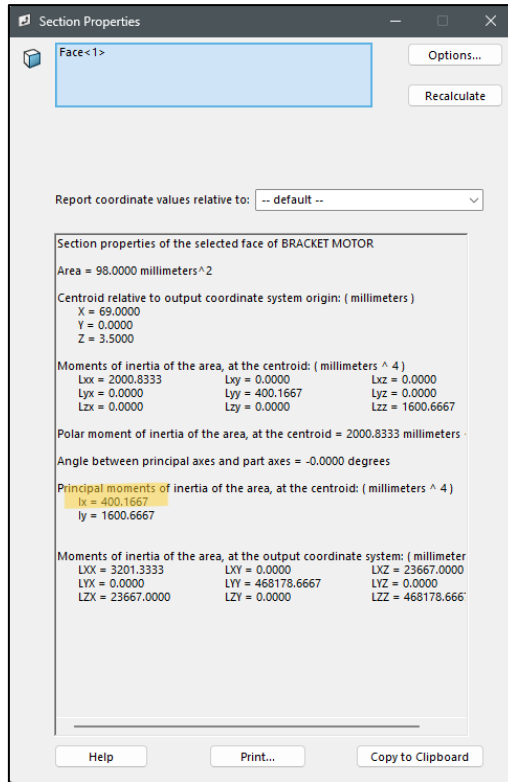

Lampiran 4.5 Berat Propeller

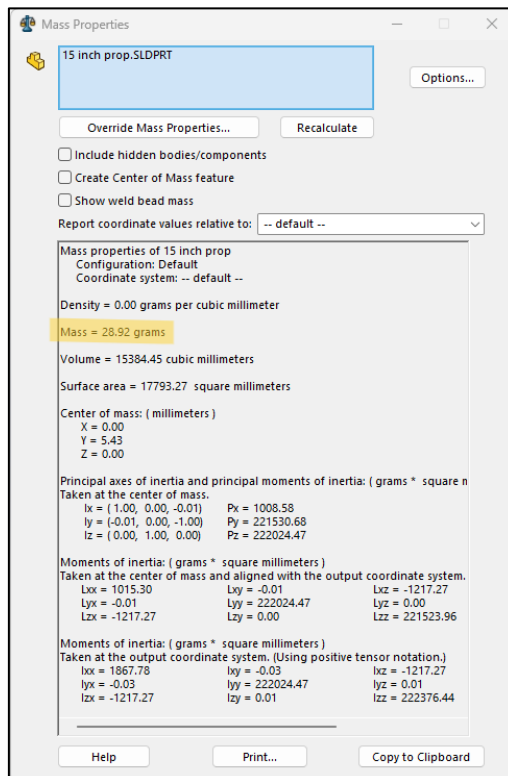

Lampiran 4.6 Berat Total Bracket Sensor

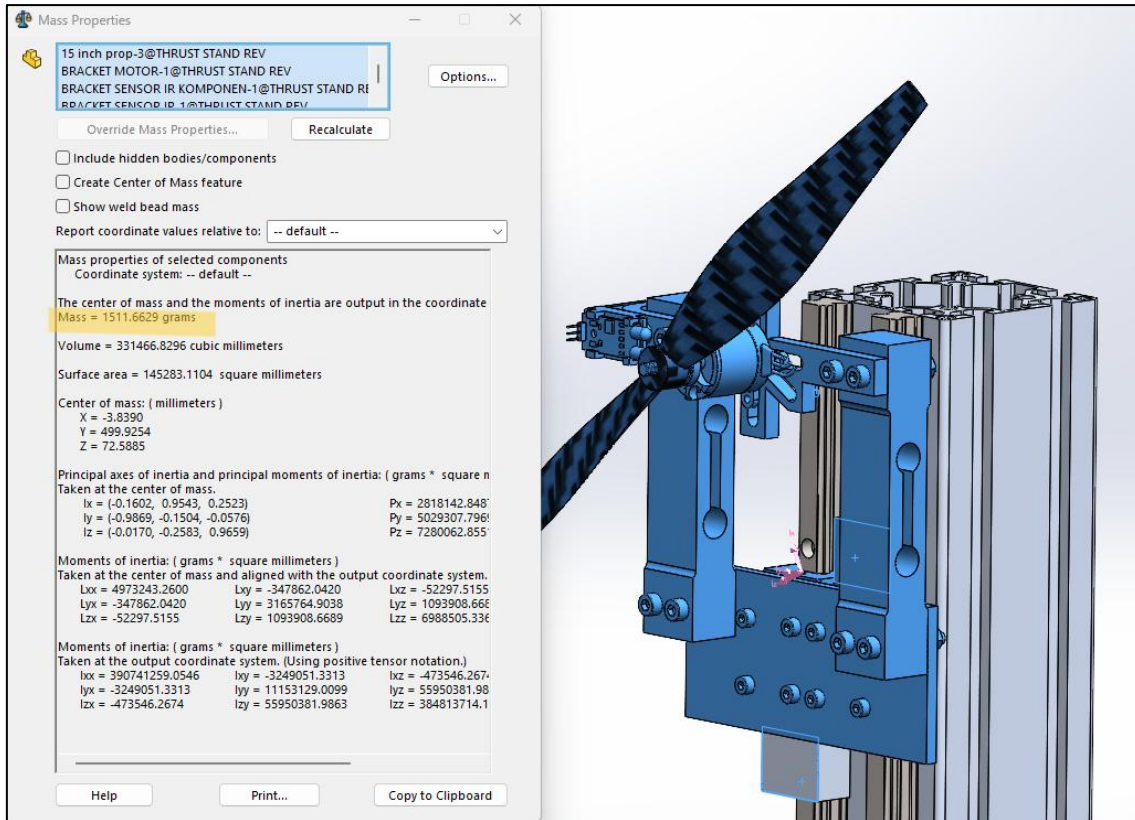

Lampiran 4.7 Beban Aksial Baut [40]

TB 8-14 Spannkraft F_{sp} und Spannmomente M_{sp} für Schaft- und Dehnschrauben bei verschiedenen Gesamtreibungszahlen μ_{ges} ¹⁾

Regel- bzw. Feingewinde	μ_{ges} = μ_G = μ_K	Schaftschrauben						Dehnschrauben ($d_T \approx 0,9 d_3$)					
		Spannkraft F_{sp} in kN			Spannmoment M_{sp} in Nm			Spannkraft F_{sp} in kN			Spannmoment M_{sp} in Nm		
		bei Festigkeitsklasse ²⁾						bei Festigkeitsklasse ²⁾					
		8.8	10.9	12.9	8.8	10.9	12.9	8.8	10.9	12.9	8.8	10.9	12.9
M5	0,08	7,6	11,1	13,0	4,4	6,5	7,6	5,3	7,8	9,1	3,1	4,5	5,3
	0,10	7,4	10,8	12,7	5,2	7,6	8,9	5,1	7,6	8,9	3,6	5,3	6,2
	0,12	7,2	10,6	12,4	5,9	8,6	10,0	5,0	7,3	8,6	4,1	6,0	7,0
	0,14	7,0	10,3	12,0	6,5	9,5	11,2	4,8	7,1	8,3	4,5	6,6	7,7
M6	0,08	10,7	15,7	18,4	7,7	11,3	13,2	7,5	11,0	12,9	5,4	7,9	9,2
	0,10	10,4	15,3	17,9	9,0	13,2	15,4	7,3	10,7	12,5	6,2	9,1	10,7
	0,12	10,2	14,9	17,5	10,1	14,9	17,4	7,0	10,3	12,1	7,0	10,3	12,0
	0,14	9,9	14,5	17,0	11,3	16,5	19,3	6,8	9,9	11,6	7,7	11,3	13,2
M8	0,08	19,5	28,7	33,6	18,5	27,2	31,8	13,8	20,3	23,8	13,1	19,2	22,5
	0,10	19,1	28,0	32,8	21,3	31,8	37,2	13,4	19,7	23,1	15,2	22,3	26,1
	0,12	18,6	27,3	32,0	24,6	36,1	42,2	13,0	19,1	22,3	17,1	25,2	29,5
	0,14	18,1	26,6	31,1	27,3	40,1	46,9	12,5	18,4	21,5	18,9	27,8	32,5

Lampiran 4.8 Koefisien Gaya Gesek [40]

TB 8-12 (Fortsetzung)

d) Haftreibungszahlen in der Trennfuge (nach VDI-Richtlinie 2230)

Stoffpaarung		Stahl-Stahl/ GS	Stahl-Stahl ¹⁾	Stahl-Stahl ²⁾	Stahl-GJL	Stahl-GJL ¹⁾	Stahl-GJS
Haftreibungszahl μ_T	trocken	0,1...0,3	0,15...0,40	0,04...0,15	0,11...0,24	0,26...0,31	0,1...0,23
	geschmiert	0,07...0,12			0,06...0,1		
Stoffpaarung		Stahl-GJS ¹⁾	GJL-GJL	GJL-GJL ³⁾	GJS-GJS	GJS-GJS ³⁾	GJL-GJS
Haftreibungszahl μ_T	trocken	0,2...0,26	0,15...0,3	0,09...0,36	0,25...0,52	0,08...0,25	0,13...0,26
	geschmiert		0,06...0,2		0,08...0,12		
Stoffpaarung		Stahl-Bronze	GJL-Bronze	Stahl-Cu-Leg.	Stahl-Al-Leg.	Alu-Alu	Alu-Alu ³⁾
Haftreibungszahl μ_T	trocken	0,12...0,28	0,28	0,07...0,25	0,7...0,28	0,19...0,41	0,1...0,32
	geschmiert	0,18	0,15...0,2		0,05...0,18	0,07...0,12	

¹⁾ gereinigt; ²⁾ einsatzgehärtet; ³⁾ gereinigt/entfettet.

Lampiran 4.9 Tabel Persamaan Slope dan Deflection pada kasus tumpuan cantilever.

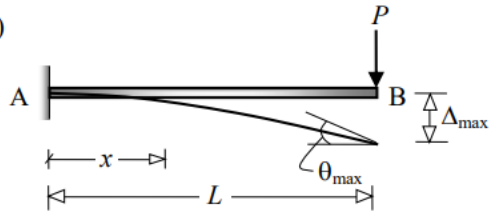
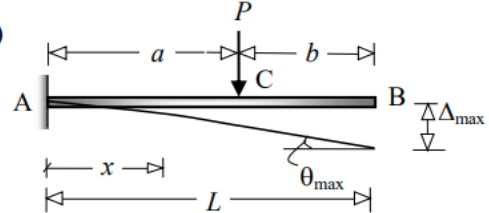
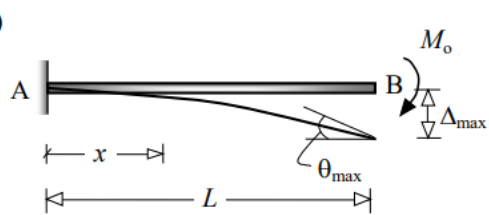
Beam type	Slope at free end	Deflection at critical location(s)
<p>a)</p> 	$\theta_{\max} = \frac{PL^2}{2EI}$	$\Delta_{\max} = \frac{PL^3}{3EI}$
<p>b)</p> 	$\theta_{\max} = \frac{Pa^2}{2EI}$	$\Delta_c = \frac{Pa^3}{3EI}$ $\Delta_{\max} = \frac{Pa^2}{6EI}(3L - a)$
<p>c)</p> 	$\theta_{\max} = \frac{M_o L}{EI}$	$\Delta_{\max} = \frac{M_o L^2}{2EI}$

Lampiran 5
(Analisis Simulasi)

Lampiran 5.1 Contoh Studi Kasus Simplifikasi

Rancangan

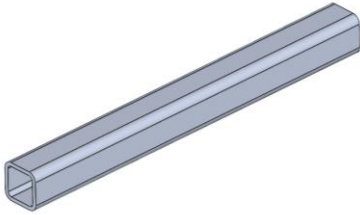
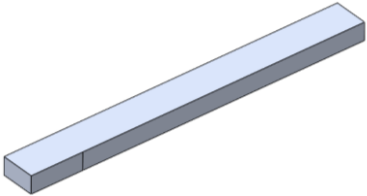
<i>HOLLOW</i>		<i>PEJAL</i>	
Ilustrasi		Ilustrasi	
			
Dimensi		Dimensi	
Panjang	400 mm	Panjang	400 mm
Lebar	40 mm	Lebar	20,765 mm
Tinggi	40 mm	Tinggi	40 mm
Momen Inersia	110.746,6174 mm ⁴	Momen Inersia	110.746,6174 mm ⁴

Kondisi Batas

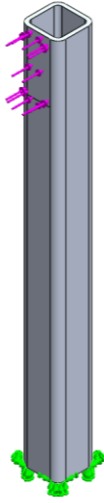
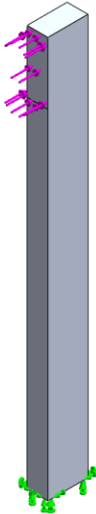
<i>HOLLOW</i>		<i>PEJAL</i>	
Ilustrasi		Ilustrasi	
			
Dimensi		Dimensi	
<i>Fixture</i>	<i>Fix</i>	<i>Fixture</i>	<i>Fix</i>
<i>External Loads</i>	100 N	<i>External Loads</i>	100 N

Konvergensi *Hollow*

Simulasi	Mesh	Max Tegangan (N/mm ²)	Solving Time (S)	Error
1	10	7,4	00:00:01	
2	9,5	7,35	00:00:01	-0,68%
3	9	7,6	00:00:01	3,29%
4	8,5	7,21	00:00:01	-5,41%
5	8	7,53	00:00:01	4,25%
6	7,5	7,41	00:00:01	-1,62%
7	7	7,54	00:00:01	1,72%
8	6,5	7,07	00:00:01	-6,65%
9	6	7,5	00:00:01	5,73%
10	5,5	7,55	00:00:01	0,66%
11	5	7,31	00:00:02	-3,28%
12	4,5	7,44	00:00:02	1,75%
13	4	7,22	00:00:02	-3,05%
14	3,5	7,24	00:00:03	0,28%
15	3	7,57	00:00:04	4,36%
16	2,5	8,07	00:00:06	6,20%
17	2	8,43	00:00:10	4,27%
18	1,5	8,26	00:00:26	-2,06%
19	1	10,9	00:01:22	24,22%

Konvergensi *Pejal*

Simulasi	Mesh	Max Tegangan (N/mm ²)	Solving Time (S)	Error
1	10	6,68	00:00:01	
2	9,5	6,84	00:00:01	2,34%
3	9	6,9	00:00:01	0,87%
4	8,5	6,78	00:00:01	-1,77%
5	8	6,77	00:00:01	-0,15%
6	7,5	6,7	00:00:01	-1,04%
7	7	6,74	00:00:01	0,59%
8	6,5	7,27	00:00:01	7,29%
9	6	7,38	00:00:01	1,49%
10	5,5	7,32	00:00:01	-0,82%
11	5	7,5	00:00:01	2,40%
12	4,5	8,03	00:00:01	6,60%
13	4	8,33	00:00:02	3,60%
14	3,5	8,6	00:00:03	3,14%
15	3	9,07	00:00:04	5,18%
16	2,5	9,84	00:00:08	7,83%

17	2	10,6	00:00:13	7,17%
18	1,5	12,9	00:00:32	17,83%

Perbandingan

No.	Nama	Simulasi <i>Hollow</i>	Simulasi Pejal	Tingkat <i>Error</i>
1.	Tegangan <i>Von Mises</i>	7,24 MPa	7,32 MPa	1,10 %

Lampiran 5.2 Konvergensi *Mesh* Rangka

Simulasi	Biggest/Smallest	No.Of Elements	Max Tegangan (N/mm2)	Error	Solving Time (S)
1	175/17,5	93	16,292	0	00:00:01
2	150/15	108	16,258	-0,21%	00:00:01
3	100/10	107	16,351	0,57%	00:00:01
4	75/10	126	15,764	-3,72%	00:00:01
5	50/10	167	14,694	-7,28%	00:00:01
6	50/5	167	14,694	0,00%	00:00:02
7	40/5	195	15,275	3,81%	00:00:02
8	30/5	504	15,371	0,62%	00:00:03
9	20/5	1162	15,414	0,28%	00:00:03
10	15/5	2098	15,567	0,99%	00:00:04

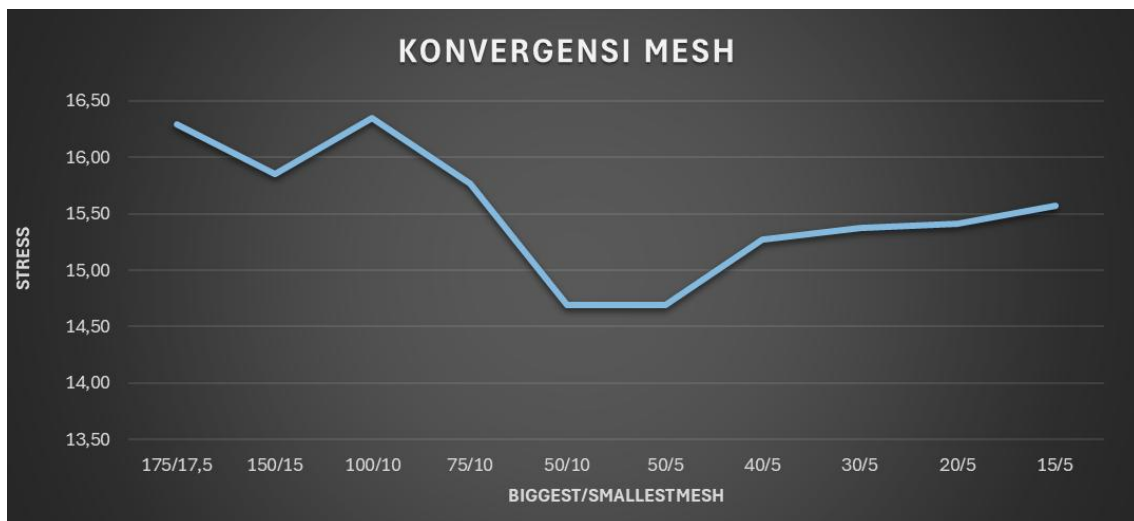

Lampiran 5.3 Konvergensi Mesh Bracket

Simulasi	Biggest/Smallest	No.Of Elements	Max Tegangan (N/mm2)	Error	Solving Time (S)
1	20/2	1373	151,033	0	00:00:01
2	15/2	1649	150,334	-0,47%	00:00:01
3	12/2	1887	146,040	-2,94%	00:00:01
4	10/2	1806	146,709	0,46%	00:00:01
5	8/2	2409	149,852	2,10%	00:00:01
6	7/2	2546	151,707	1,22%	00:00:01
7	6/2	3005	149,298	-1,61%	00:00:01
8	5/2	3055	151,880	1,70%	00:00:01
9	5/1	3071	150,649	-0,82%	00:00:01
10	4/1	2940	150,875	0,15%	00:00:01
11	3/1	4857	150,725	-0,10%	00:00:01
12	2/1	13531	150,905	0,12%	00:00:01

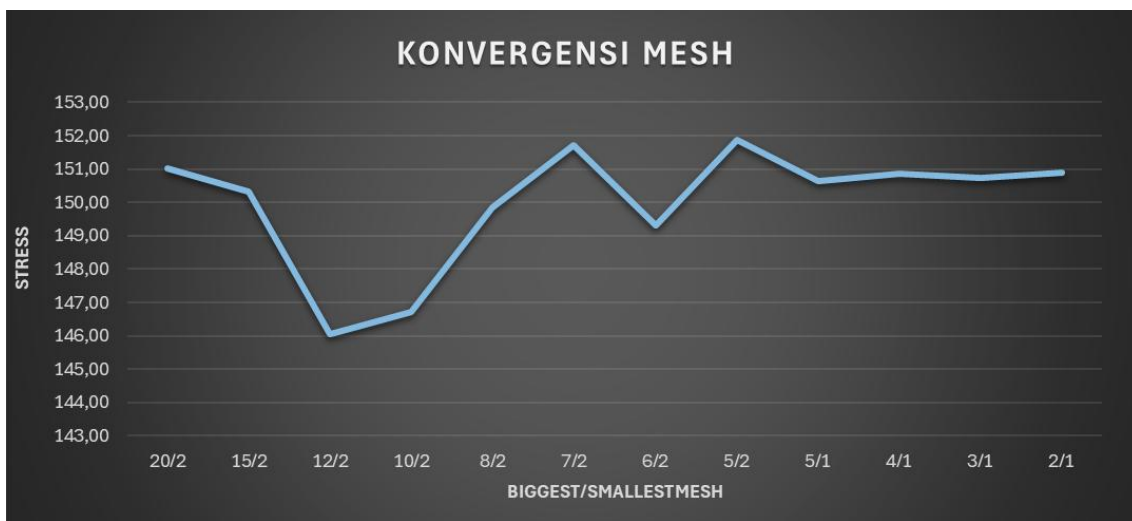

Lampiran 6
(Harga Komponen & Fabrikasi)

Lampiran 6.1 Harga Aluminium Profile 4080



Aluminium Profil 4080 Silver T-Slot 40 Series - Per 1 CM

Aluminium Profil 4080 Silver T-Slot 40 Series - Per 1 CM

Terjual 10 rb+ • ★ 5 (28 rating)

Rp3.500

[Detail](#) [Spesifikasi](#) [Info Penting](#)

Kondisi: Baru
 Min. Pemesanan: 20 Buah
 Etalase: **Aluminium Profile 1**

Aluminium Profil 4080 T-Slot 40 x 40 Series Panjang Max 3 Meter
 JNE : 3 Meter Rex : 3 Meter Pos : 150CM J amp,t : 100CM ID Expres : 100CM Material : Anodised Aluminium (6063-T5) Harga Per 1 CM
 Harap dibaca terlebih dahulu! Minium Pemesanan 20 CM Untuk pemesanan dibawah 20 CM terkena biaya pemotongan Biaya pemotongan : <https://tokopedia.com/lajarus teknik/add-cost-biaya-tambahan-2000> Jarak pemotongan kurang lebih 5mm Lebihkan pesanan agar potongan presisi Tuliskan ukuran pemotongan pada...
[Lihat Selengkapnya](#)

Atur jumlah dan catatan

— 75 + Stok Total: 7332

Min. pembelian 20 pcs

Subtotal **Rp262.500**

[+ Keranjang](#)

[Beli Langsung](#)

[Chat](#) [Wishlist](#) [Share](#)

 **Lajarus Teknik** [Follow](#)

★ 4.9 (22,7 rb)
 ⌚ ± 5 jam pesanan diproses

Lampiran 6.2 Harga Alumunium Profile 8080



Aluminium Profile T slot 8080 Double Slot Per Centi Termurah

Aluminium Profile T slot 8080 Double Slot Per Centi Termurah

Terjual 10 rb+ • ★ 4.7 (15 rating)

Rp5.841

[Detail](#) [Spesifikasi](#) [Info Penting](#)

Kondisi: Baru
 Min. Pemesanan: 10 Buah
 Etalase: **ALUMINIUM ALL TYPE PER CENTI**

- Aluminium Profile 8080
 - Untuk frame mesin saat baik dan kokoh
 - Dan sangat Flexibel pembelian di Toko Fani Al mudah komunikasi dan fast respon
 - Lebar slot 8
 - Panjang 1 per centi
 - Finishing anodized
 - Minimum Pemotong 20cm agar tidak kena charge potong...
[Lihat Selengkapnya](#)

Atur jumlah dan catatan

— 60 + Stok Total: 999934

Min. pembelian 10 pcs

Subtotal **Rp350.460**

[+ Keranjang](#)

[Beli Langsung](#)

[Chat](#) [Wishlist](#) [Share](#)

 **Fani Aluminium Profile** [Follow](#)

★ 5.0 (5,4 rb)
 ⌚ ± 5 jam pesanan diproses

Lampiran 6.3 Harga Linear Rail Guide



TRH15 - TRH 15 SRF Linear Rail Guide Per 1 Cm

TRH15 - TRH 15 SRF Linear Rail Guide Per 1 Cm

Terjual 10 rb+ • ★ 5 (39 rating)

Rp3.250

~~Rp3.400~~

[Detail](#) [Info Penting](#)

Kondisi: Baru
 Min. Pemesanan: 20 Buah
 Etalase: **SRF - TRH Linear Rail Bearing Block 1**

TRH 15 - SRF 15 - HGR 15

Type : TRH Linear Motion Rail Guide
 Model number : TRH15
 Lebar Rail 15mm
 Tinggi Rail 15mm...
[Lihat Selengkapnya](#)

Atur jumlah dan catatan

— 88 + Stok Total: 31820

Min. pembelian 20 pcs

Subtotal **Rp286.000**

[+ Keranjang](#)

[Beli Langsung](#)

[Chat](#) [Wishlist](#) [Share](#)

 **Lajarus Teknik** [Follow](#)

★ 4.9 (22,7 rb)
 ⌚ ± 5 jam pesanan diproses

Lampiran 6.4 Harga *Linear Bearing Block*



TRH15B - TRH 15 B SRF Linlear Bearing Block
Terjual 500+ • 5 (54 rating)

Rp90.000
14% Rp105.000

Detail Info Penting

Kondisi: Baru
Min. Pemesanan: 1 Buah
Etalase: **SRF - TRH Linear Rail Bearing Block 1**

Features:
Strong and durable.
The tool is simple and easy to use.
Professional and technical.
Small size, lightweight, especially for small equipment.
Slider can be moved easily and smoothly.
With steel ball holder/retainer.
Fit for: Semiconductor manufacturing equipment, printed circuit...
[Lihat Selengkapnya](#)

 **Lajarus Teknik** [Follow](#)

☆ 4.9 (22,7 rb)
⌚ ± 5 jam pesanan diproses

Atur jumlah dan catatan

− 2 + Stok Total: 399

Subtotal **Rp180.000**

[+ Keranjang](#)

[Beli Langsung](#)

Chat | Wishlist | Share

Lampiran 6.5 Harga *T-Slot 4040 M6*



T Slot 4040 M6 Untuk Aluminium Profile
Terjual 1 rb+ • 4.9 (13 rating)

Rp3.000
25% Rp4.000

Detail Info Penting

Kondisi: Baru
Min. Pemesanan: 1 Buah
Etalase: **Aluminium Aksesoris 1**

 **Lajarus Teknik** [Follow](#)

☆ 4.9 (22,7 rb)
⌚ ± 5 jam pesanan diproses

Atur jumlah dan catatan

− 12 + Stok Total: 3848

Subtotal **Rp36.000**

[+ Keranjang](#)

[Beli Langsung](#)

Chat | Wishlist | Share



in-lite Lampu Hemat Energi Berkualitas

Lampiran 6.6 Harga *Bracket Corner 8080*



Alumunlum Bracket Corner Siku 8080 / Gusset corner Profile 8080
Terjual 250+ • 4.9 (18 rating)

Rp52.000

Detail

Kondisi: Baru
Min. Pemesanan: 1 Buah
Etalase: **Aluminium Profile and Acc**

Gusset Corner bracket 8080 / Bracket Aluminium Profile,
untuk aluminium profile size 8080,
terbuat dari anodized aluminium,
size : 78mm x 78mm x 78mm, untuk size detail silakan mengacu pada foto kedua pada postingan.
tersedia juga gusset untuk size lain ...
[Lihat Selengkapnya](#)

 **Lean Sigma** [Follow](#)

☆ 5.0 (6,6 rb)
⌚ ± 3 jam pesanan diproses

Atur jumlah dan catatan

− 3 + Stok Total: 293

Subtotal **Rp156.000**

[+ Keranjang](#)

[Beli Langsung](#)

Chat | Wishlist | Share



in-lite Lampu Hemat Energi Berkualitas

Lampiran 6.7 Harga Bracket Corner 2020



BRACKET CORNER 2020

2020 adalah merek, gambar adalah, dan ukuran.

Lajarus Teknik

2020 bracket corner / gusset element / siku aluminum - 1pcs
10 rb+ barang berhasil terjual

Rp3.000

Pilih ukuran: 1pcs

1pcs 10pcs

Detail Spesifikasi Panduan Info Penting

Kondisi: Baru
Min. Pemesanan: 1 Buah
Etalase: **Aluminium Aksesoris 1**

Harga per pc

size 2020
(pakai baut screw M5 tersedia di etalase) max M6

 **Lajarus Teknik** Follow

4.9 (22,7 rb)
± 5 jam pesanan diproses

Atur jumlah dan catatan

1pcs

- 2 + Stok: 7.791

Subtotal **Rp6.000**

+ Keranjang

Beli Langsung

Chat Wishlist Share

in-lite Lampu Hemat Energi Berkualitas

Lampiran 6.8 Harga T-Slot 4040 M4



ALUMINIUM PROFILE 4040 M4

T-Sliding 4040 STANDARD SPEK 3D PRO

T-Sliding 4040 M4

T Nut M4 Tee Nut T Sliding Nut 40-M4 Square Aluminium Profile 4040
Terjual 250+ • 5 (2 rating)

Rp2.000

Detail

Kondisi: Baru
Min. Pemesanan: 10 Buah
Etalase: **T Sliding Nut**

T Sliding Nut Square M4
Untuk Aluminium Profile 4040

Harga satuan
Stock Ready

 **3D PRO** Follow

5.0 (1,9 rb)
± 4 jam pesanan diproses

Atur jumlah dan catatan

- 10 + Stok Total: 2500

Min. pembelian 10 pcs

Subtotal **Rp20.000**

+ Keranjang

Beli Langsung

Chat Wishlist Share

in-lite Lampu Hemat Energi Berkualitas

Lampiran 6.9 Harga Load Cell 80kg



Strain gauge pressure sensor
Single point loadcell
Load cell sensor

Automa-88

CZL-601
Cap. 3kg / 10kg / 20kg / 40kg / 80kg

Loadcell 13cm x 2.8cm x 2.2cm load cell cap 3kg 10kg 20kg 40kg 80kg - Cap. 80kg
250+ barang berhasil terjual

Rp150.000

Pilih ukuran: Cap. 80kg

Cap. 3kg Cap. 10kg Cap. 20kg Cap. 40kg

Cap. 80kg Cap. 6kg

Detail Info Penting

Kondisi: Baru
Min. Pemesanan: 1 Buah
Etalase: **Timbangan Weighing Controller/ Indicator & Load cell Se...**

*** READY STOCK. SILAHKAN LANGSUNG DI ORDER ***
LOADCELL SENSOR CAPACITY 20KG SPARE PART TIMBANGAN DIGITAL *** DIMENSI 130(p) x 28(l) x 22(t) dalam mm *** MOHON DIBACA NOTE KAMI DIBAWAH. UNTUK TEKNISI TIMBANGAN DIGITAL BUKAN UNTUK ORANG AWAM YG COBA-COBA JADI TEKNISI ***
Silahkan order sesuai kapasitas loadcell pada variant produk: 3kg, 10kg, 20kg, 40kg, 80kg Note: - Loadcell ini 100% baru dan Barang yg kami kirim sudah lolos QC dan tidak bergaransi. - Spare part ini...
[Lihat Selengkapnya](#)

 **Automa-88** Follow

4.9 (32,9 rb)
± 5 jam pesanan diproses

Atur jumlah dan catatan

Cap. 80kg

- 2 + Stok: 190

Subtotal **Rp300.000**

+ Keranjang

Beli Langsung

Chat Wishlist Share

in-lite Lampu Hemat Energi Berkualitas

Lampiran 6.10 Harga Battery Lipo 3s 3300 mAh 65C XT60



Dinogy Baterai Lipo 3S Graphene 3300mAh 65C XT60 Battery Drone Batre
Terjual 11 • 5 (5 rating)

Rp520.000

Detail Info Penting

Kondisi: Baru
Min. Pemesanan: 1 Buah
Etalase: **BATERAI LIPO**

Specifications Cell: Lithium polymer Capacity: 3300mah
Voltage: 11.1V/3S Continuous rate: 65C Size: - tebal 22 x lebar/tinggi 42 x panjang136mm Weight: - 263 g Package Included:
1 Dinogy Graphene 11.1V 3300mAh 65C XT60

Buaya Aeratech Follow
4.9 (14,5 rb)
± 5 jam pesanan diproses

Atur jumlah dan catatan

1 Stok Total: **Sisa 3**

Subtotal **Rp520.000**

+ Keranjang

Beli Langsung

Chat Wishlist Share

Lampiran 6.11 Harga Motor Sunnysky X2216



Sunnysky X Series V3 X2216 1250KV Long/Short Shaft 3-4S Brushless Motor for RC Drone Airplane - Short Shaft
10 barang berhasil terjual

Rp425.000

Pilih jenis shaft: Short Shaft

Long Shaft **Short Shaft**

Detail Info Penting

Kondisi: Baru
Min. Pemesanan: 1 Buah
Etalase: **MOTOR BRUSHLESS - ACC**

X2216 KV1250III Short shaft / Long Shaft
Specification :
- Stator Diameter : 22mm
- Stator Thickness : 16mm
- No.of Stator Slots : 12
- No.of Rotor Poles : 14
- Motor Kv : 1250
- No-load current : 1A/10V...

Buaya Aeratech Follow
4.9 (14,5 rb)
± 5 jam pesanan diproses

Atur jumlah dan catatan

Short Shaft

1 Stok: **Sisa 8**

Subtotal **Rp425.000**

+ Keranjang

Beli Langsung

Chat Wishlist Share

Lampiran 6.12 Harga Propeller 15 in



Gemfan 15x5.5 T-Type Carbon Fiber Propeller CW-CCW (1 Pair)
Terjual 100+ • 5 (18 rating)

Rp338.800

Detail Spesifikasi Info Penting

Kondisi: Baru
Min. Pemesanan: 1 Buah
Etalase: **Propellers**

SELAMA PRODUK TERPOSTING/TERLIHAT BERARTI READY STOCK !!!
LANGSUNG ORDER, TIDAK PERLU KONFIRMASI LAGI.

Patented Balance Technique.
• Low Noise, High Quality Propellers
• Light and Easy to Install...

Aerofly Hobbies Follow
5.0 (5,7 rb)
± 2 jam pesanan diproses

Atur jumlah dan catatan

1 Stok Total: **19**

Subtotal **Rp338.800**

+ Keranjang

Beli Langsung

Chat Wishlist Share

Lampiran 6.13 Harga Propeller 5 in

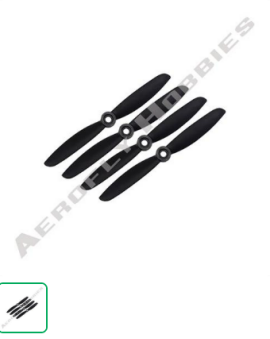

GemFan 5x4.5 Normal Rotation Propeller Black (4 Pcs)
Terjual 8 • 4.3 (3 rating)

Rp24.800

[Detail](#) [Info Penting](#)

Kondisi: Baru
Min. Pemesanan: 1 Buah
Etalase: [Race Drone](#)

SELAMA PRODUK TERPOSTING/TERLIHAT BERARTI READY STOCK !!! LANGSUNG ORDER, TIDAK PERLU KONFIRMASI LAGI.

=====

These are 4 Pcs of GemFan 5x4.5 Normal Rotation Propeller.

GemFan produces high quality propellers for Airplane and Multi-...
[Lihat Selengkapnya](#)

 **Aerofly Hobbies** [Follow](#)

☆ 5.0 (5,7 rb)
⌚ ± 2 jam pesanan diproses

Atur jumlah dan catatan

— 4 + Stok Total: 14

Subtotal **Rp99.200**

[+ Keranjang](#)

[Beli Langsung](#)

[Chat](#) | [Wishlist](#) | [Share](#)

Lampiran 6.14 ESC Hobbywing Skywalker 50A V2



Hobbywing Skywalker 50A V2
Terjual 100+ • 4.8 (49 rating)

Rp350.000

[Detail](#) [Info Penting](#)

Kondisi: Baru
Min. Pemesanan: 1 Buah
Etalase: [ESC - UBEC - BEC](#)

ESC seri Skywalker dibuat dengan komponen berkualitas dan reliabilitas yang tinggi, dengan adanya LED program card, anda bisa memprogram ulang parameter yang ada sesuai kebutuhan anda. Terdapatnya beragam fitur pengaman seperti deteksi voltase input yang abnormal, ESC Thermal, Fail Safe, dan low voltage cut off, secara efektif akan meningkatkan masa pakai dari ESC ini. Selain itu ESC ini kompatibel dengan baterai LIPO maupun NIMH. Spesifikasi: - Output berkelanjutan: 50A - Burst saat ini: 50A/65A - Masukan daya...

[Lihat Selengkapnya](#)

 **Buaya Aerotech** [Follow](#)

☆ 4.9 (14,5 rb)
⌚ ± 5 jam pesanan diproses

Atur jumlah dan catatan

— 1 + Stok Total: 19

Subtotal **Rp350.000**

[+ Keranjang](#)

[Beli Langsung](#)

[Chat](#) | [Wishlist](#) | [Share](#)

Lampiran 6.15 Harga Arduino Nano

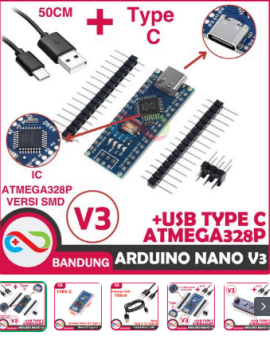

ARDUINO NANO V3.0 ATMEGA328P TYPE-C PLUS KABEL CH340 HQ IC ORIGINAL
Terjual 1 rb+ • 5 (396 rating)

Rp64.600

[Detail](#) [Info Penting](#)

Kondisi: Baru
Min. Pemesanan: 1 Buah
Etalase: [ARDUINO-MCU-PROGRAMER](#)

BRD-0011
=====

Deskripsi:
=====

Walaupun otaknya sama dengan UNO, menggunakan ATmega328P, Arduino NANO ini berukuran lebih kecil dan compact. Fungsionalitas si kecil NANO ini mirip dengan abangnya UNO dan Duemilanove...

[Lihat Selengkapnya](#)

 **CNC STORE BANDUNG** [Follow](#)

☆ 4.9 (413,2 rb)
⌚ ± 40 menit pesanan diproses

Atur jumlah dan catatan

— 1 + Stok Total: 227

Subtotal **Rp64.600**

[+ Keranjang](#)

[Beli Langsung](#)

[Chat](#) | [Wishlist](#) | [Share](#)

Lampiran 6.16 Harga Sensor Arus



30A
BANDUNG Sensor Arus ACS712

[CNC] CNC - SENSOR ARUS 30A CURRENT ACS712 ACS712ELC-30A MODULE
 Terjual 3 rb+ • ⭐ 4.9 (354 rating)

Rp15.900

Detail Info Penting

Kondisi: Baru
 Min. Pemesanan: 1 Buah
 Etalase: **SENSOR-TRANSDUCER-INPUT**

SEN-0035
 =====

Deskripsi:
 =====
 ACS712 30A DC / AC HALL CURRENT SENSOR adalah modul sensor pengukur arus listrik menggunakan prinsip hall sensor. Modul ini menggunakan chip ACS712-30 yang dapat mengukur arus AC/DC...
[Lihat Selengkapnya](#)

 **CNC STORE BANDUNG**
Follow

☆ 4.9 (413,2 rb)
 ⌚ ± 40 menit pesanan diproses

Atur jumlah dan catatan

- 1 + Stok Total: 60

Subtotal **Rp15.900**

+ Keranjang

Beli Langsung

Chat Wishlist Share

Lampiran 6.17 Sensor Infrared



Infrared Barrier Module
BANDUNG IR Obstacle Sensor

[CNC] INFRARED BARRIER OBSTACLE SENSOR HALANGAN RINTANGAN MODULE
 Terjual 10 rb+ • ⭐ 4.9 (1,388 rating)

Rp4.500

Detail Info Penting

Kondisi: Baru
 Min. Pemesanan: 1 Buah
 Etalase: **SENSOR-TRANSDUCER-INPUT**

SEN-0018
 =====

Description:
 =====
 INFRARED BARRIER OBSTACLE SENSOR ini merupakan sebuah sensor pendeteksi halangan nih gan, dengan konsep pemantulan cahaya infrared pada jarak tertentu maka pantulannya akan di terim...
[Lihat Selengkapnya](#)

 **CNC STORE BANDUNG**
Follow

☆ 4.9 (413,2 rb)
 ⌚ ± 40 menit pesanan diproses

Atur jumlah dan catatan

- 1 + Stok Total: 1010

Subtotal **Rp4.500**

+ Keranjang

Beli Langsung

Chat Wishlist Share

Lampiran 6.18 Harga Emergency Push Button



LA38-11ZS
BANDUNG Stop Self Locking Push Button Emergency Push Button

PUSH BUTTON EMERGENCY STOP SELF LOCKING 22MM 10A UPTO 660VAC LA38-11ZS
 Terjual 500+ • ⭐ 5 (61 rating)

Rp12.900

Detail Spesifikasi Info Penting

Kondisi: Baru
 Min. Pemesanan: 1 Buah
 Etalase: **SWITCH SAKLAR PUSH**

SWI-0045
 =====

Deskripsi:
 =====
 Push Button Emergency Stop Self Locking 22mm 10A adalah sebuah alat yang dirancang untuk memberikan fungsi darurat berhenti pada...
[Lihat Selengkapnya](#)

 **CNC STORE BANDUNG**
Follow

☆ 4.9 (413,2 rb)
 ⌚ ± 40 menit pesanan diproses

Atur jumlah dan catatan

- 1 + Stok Total: 75

Subtotal **Rp12.900**

+ Keranjang

Beli Langsung

Chat Wishlist Share

 **in-lite**
 Lampu Hemat Energi Berkualitas

Lampiran 6.19 Harga Modul HX711



**LOAD CELL AMPLIFIER
LOAD CELL CONVERSION**

BANDUNG HX711 MODULE

**MODULE HX711 HX-711 AMPLIFIER LOAD CELL ADC
CONVERTER SENSOR BERAT**

Terjual 2 rb+ • 5 (255 rating)

Rp8.000

[Detail](#) [Spesifikasi](#) [Info Penting](#)

Kondisi: Baru
Min. Pemesanan: 1 Buah
Etalase: **SENSOR-TRANSDUCER-INPUT**

SEN-0063
=====

Deskripsi:
=====

Kita ada barang baru nih akang teteh sekalian, yaitu modul HX711 yang selalu berpasangan dengan Load cell, modul HX711 ini berfungsi sebagai amplifier / penguat hasil pembacaan sensor bera...
[Lihat Selengkapnya](#)

 **CNC STORE BANDUNG** Follow

☆ 4.9 (413,2 rb)
⌚ ± 40 menit pesanan diproses

Atur jumlah dan catatan

- 2 + Stok Total: 215

Subtotal **Rp16.000**

+ Keranjang

Beli Langsung

Chat | Wishlist | Share

Lampiran 6.20 Harga Fabrikasi Alat



CV. Kawan Tekno Nusantara
Ruko Aria Graha Regency No. 1, Jl. Aria Utama,
Metro Soekarno Hatta, Bandung - 40292
Telp. / Fax. 022 - 87315000 Email : nusantara@kawanitekno.com

FR.ME.15.24
Rev.00

Bandung, 03 Juni 2025

DARI / KEPADA :
Bpk. Faza - POLMAN
.....
Di
.....
Tempat
.....

SURAT PESANAN BARANG

No. : 09/SPB-ENG/VI/25

Bersama ini kami memesan barang-barang sebagai berikut :

No.	Uraian Barang	Banyaknya	Harga Satuan	Jumlah
1	Manual Clamp Drone Thrust Stand DTS-04	2 Pcs	450,000	900,000
2	Bracket Sensor Load Cell Drone Thrust Stand DTS-05	1 Pcs	270,000	270,000
3	Bracket Sensor Drone Thrust Standl DTS-06	1 Pcs	400,000	400,000
4	Adjuster Sensor Infrared Drone Thrust Stand DTS-07	1 Pcs	170,000	170,000
Sub Total :				1,740,000
Diskon 10%				174,000
Total				1,566,000

Terbilang : # **Satu Juta Lima Ratus Enam Puluh Enam Ribu Rupiah** #

Total 1,566,000

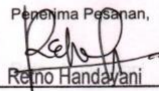
Penerima Pesanan,

Retno Handayani

Pemesan,

Lampiran 6.21 Total Harga Alat

DOMAIN MEKANIK						
No.	Nama Komponen	Spesifikasi	Jumlah	Satuan	Harga	Total Harga
1	Aluminium Profile	4080	75	pcs	Rp 3.500	Rp 262.500
2	Aluminium Profile	8080	60	pcs	Rp 5.841	Rp 350.460
3	Linear Rail Guide	TRH 15 SRF	88	pcs	Rp 3.250	Rp 286.000
4	Linear Bearing Block	TRH 15 B SRF	2	pcs	Rp 90.000	Rp 180.000
5	T-Slot	4040 M6	12	pcs	Rp 3.000	Rp 36.000
6	T-Slot	4040 M4	10	pcs	Rp 2.000	Rp 20.000
7	Bracket Corner	8080	3	pcs	Rp 52.000	Rp 156.000
8	Bracket Corner	2020	2	pcs	Rp 3.000	Rp 6.000
9	Manual Clamp	DTS-04	2	pcs	Rp450.000	Rp 900.000
10	Bracket Sensor Load Cell	DTS-05	1	pcs	Rp270.000	Rp 270.000
11	Bracket Motor	DTS-06	1	pcs	Rp400.000	Rp 400.000
12	Bracket Sensor Infrared	DTS-07	1	pcs	Rp170.000	Rp 170.000
DOMAIN ELEKTRONIK						
No.	Nama Komponen	Spesifikasi	Jumlah	Satuan	Harga	Total Harga
9	Load Cell	80 kg	2	pcs	Rp150.000	Rp 300.000
10	Battery Lipo 3s	3300 mAh	1	pcs	Rp520.000	Rp 520.000
11	Motor Drone	Sunnysky X2216	1	pcs	Rp425.000	Rp 425.000
12	Propeller	15 in	1	pcs	Rp338.800	Rp 338.800
13	Propeller	5 in	4	pcs	Rp 24.800	Rp 99.200
14	Electronic Speed Control	Hobbywings Skywalker 50A V2	1	pcs	Rp350.000	Rp 350.000
15	Microcontroller	Arduino Nano	1	pcs	Rp 64.600	Rp 64.600
16	Sensor Arus	ACS712-30A	1	pcs	Rp 15.900	Rp 15.900
17	Sensor RPM	Infrared	1	pcs	Rp 4.500	Rp 4.500
18	Emergency Push Button	LA38-11ZS	1	pcs	Rp 12.900	Rp 12.900
19	Modul Load Cell	HX711	2	pcs	Rp 8.000	Rp 16.000
TOTAL						Rp5.183.860

Lampiran 7
(Draft & Gambar Kerja)

4			3			2			1		
NO	PERUBAHAN	TANGGAL	NAMA	NO	PERUBAHAN	TANGGAL	NAMA	NO	PERUBAHAN	TANGGAL	NAMA
-	-	-	-	-	-	-	-	-	-	-	-

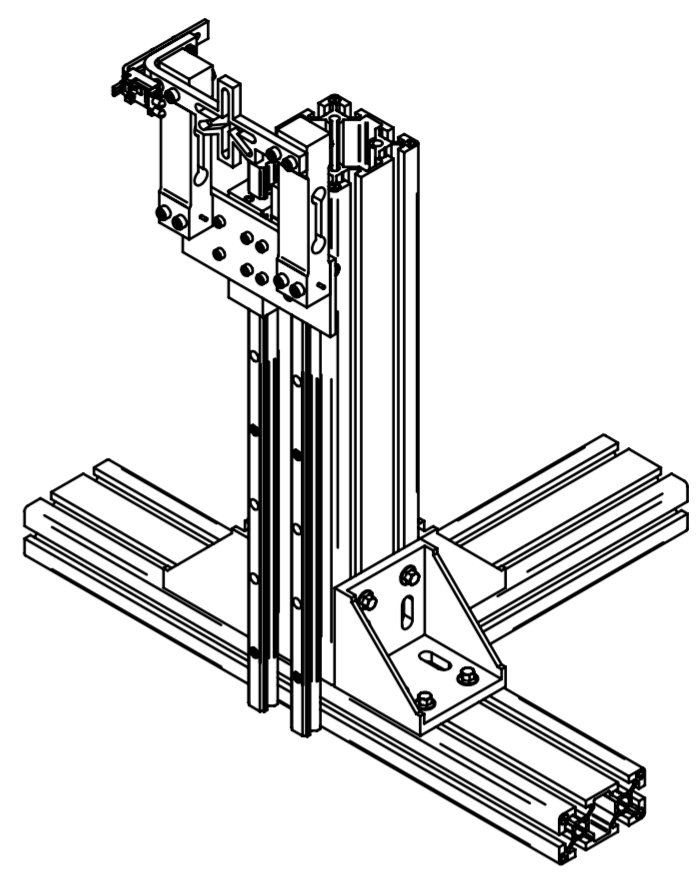
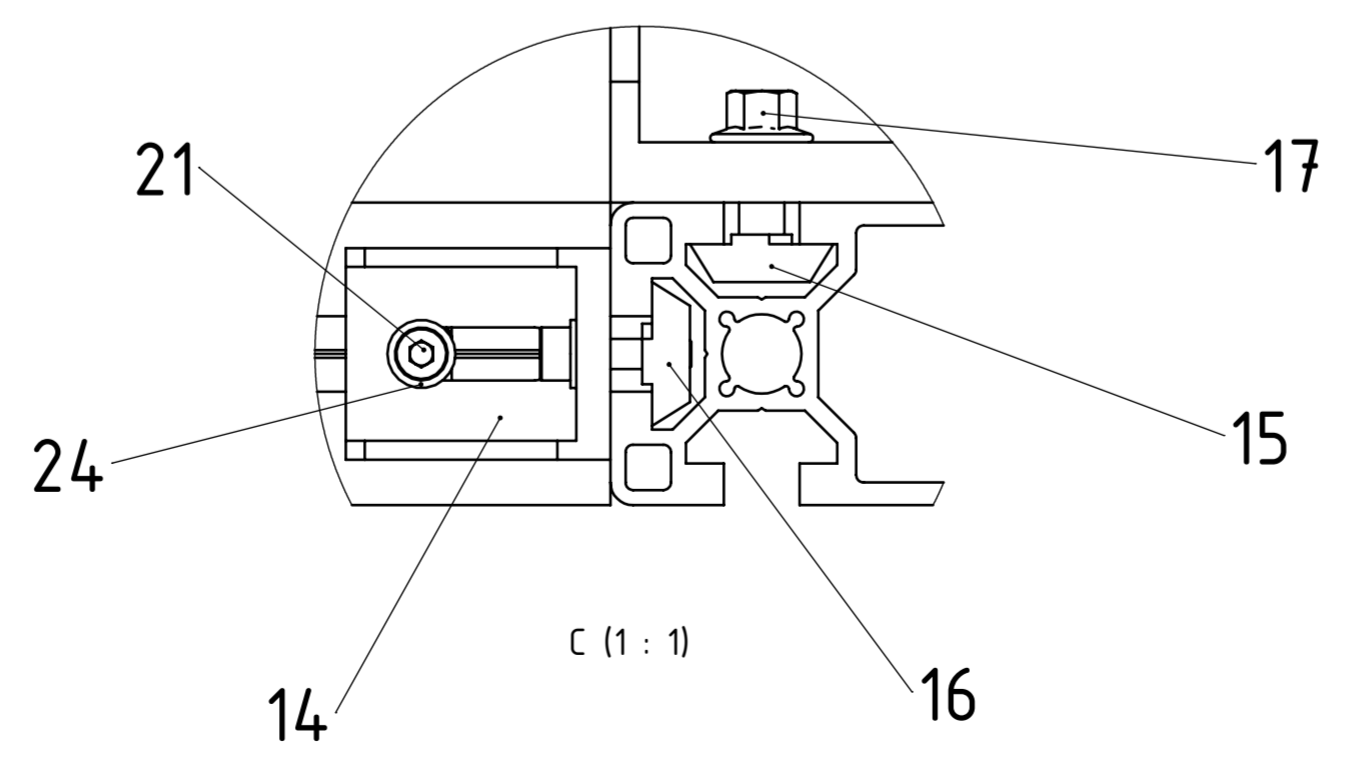
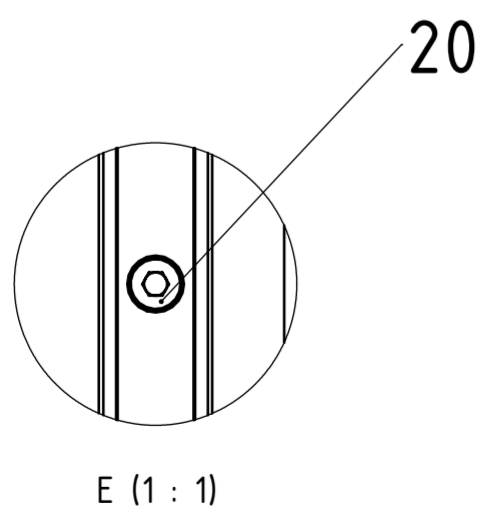
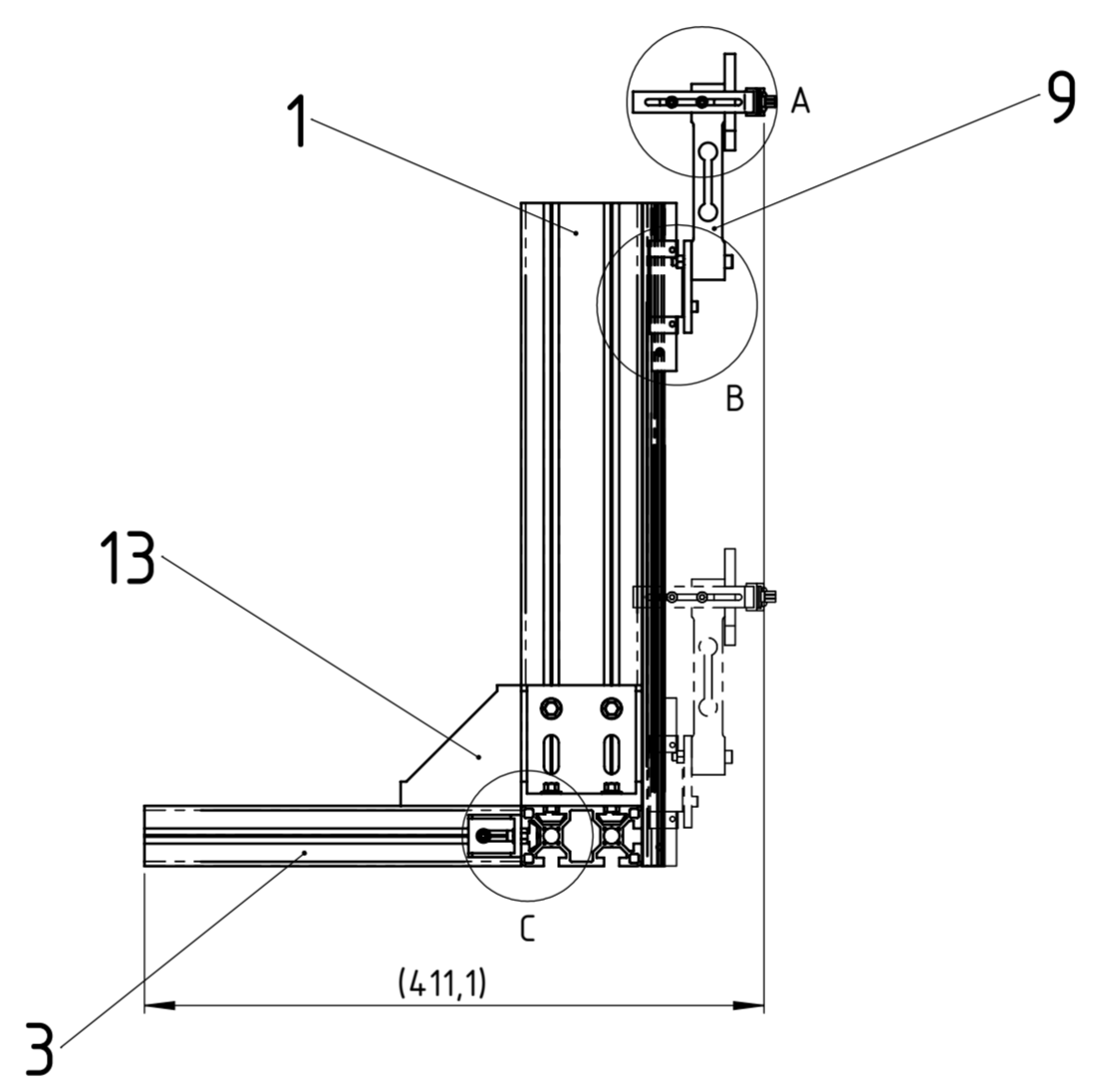
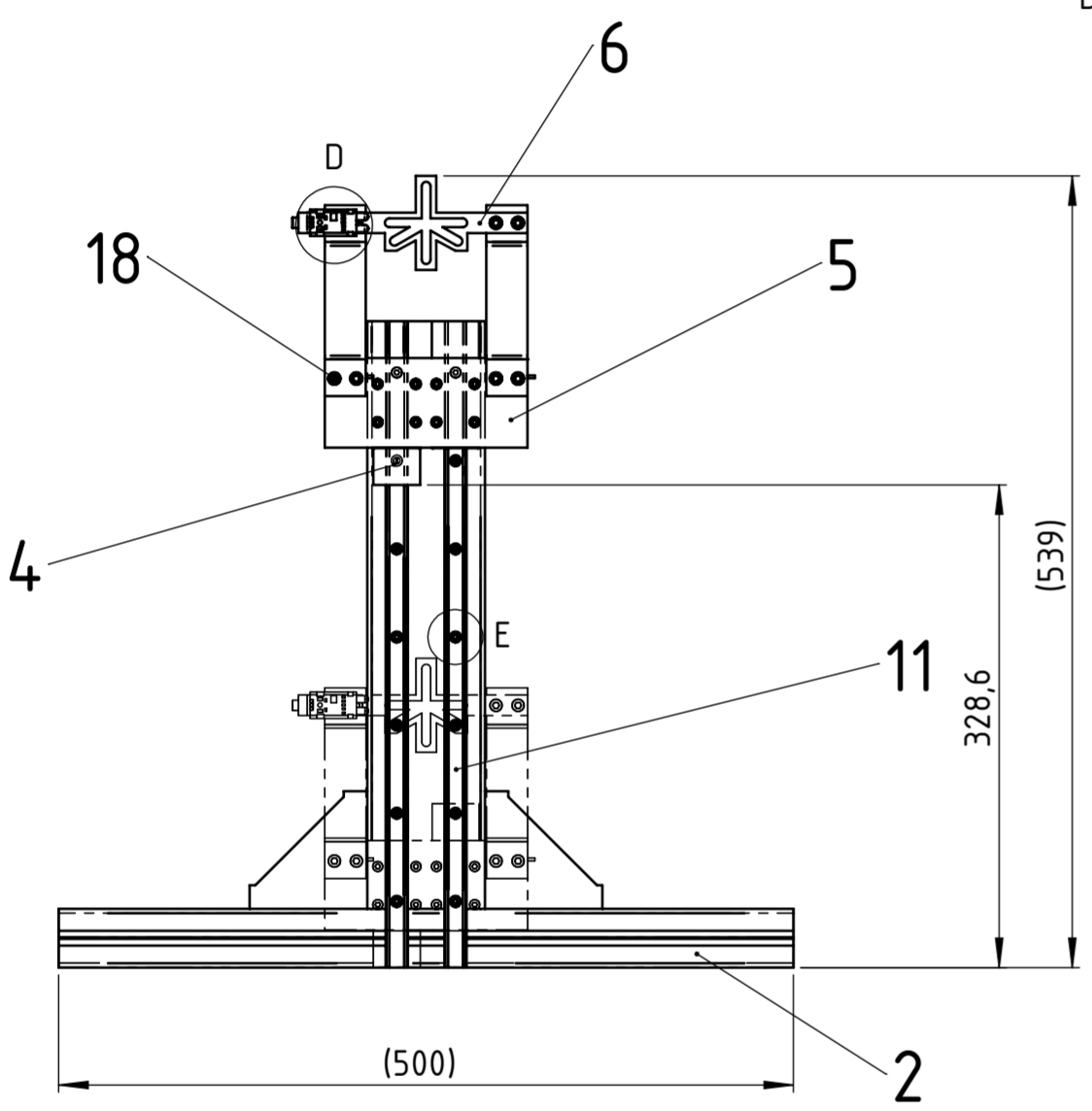
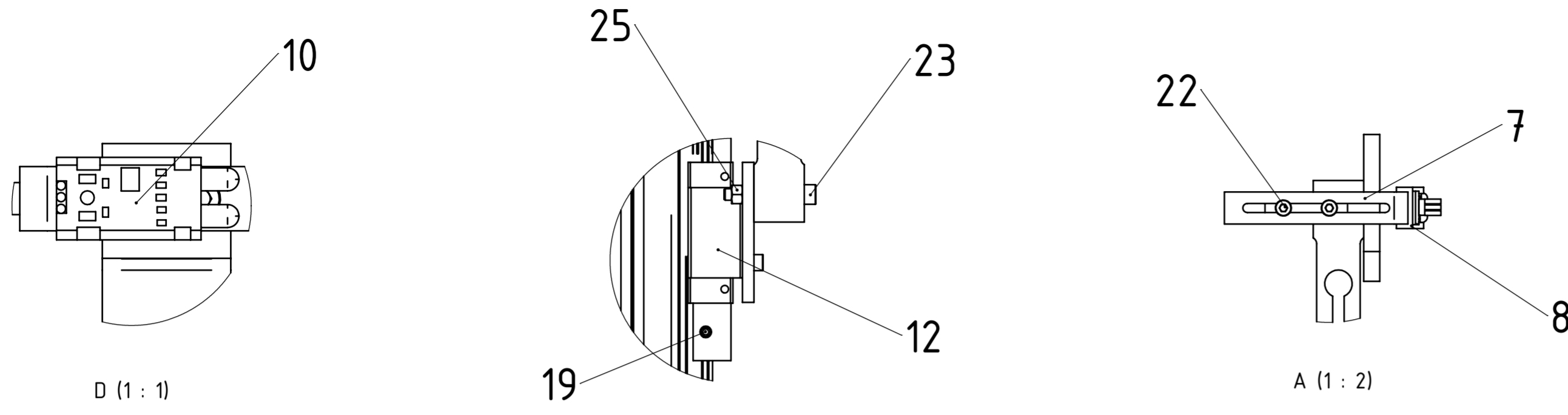

8	MUR SEGIENAM	25	-	M5X8	-	-	-	ISO 4032	-
4	WASHER	24	-	Ø4,3/8X0,8	-	-	-	ISO 7089	-
8	BAUT INBUS	23	-	M4X8	-	-	-	ISO 4762	-
2	BAUT INBUS	22	-	M4X12	-	-	-	ISO 4762	-
4	BAUT INBUS	21	-	M4X16	-	-	-	ISO 4762	-
6	BAUT INBUS	20	-	M4X20	-	-	-	ISO 4762	-
2	BAUT PENA INBUS UJUNG RATA	19	-	M5X8	-	-	-	ISO 4026	-
8	BAUT INBUS	18	-	M5X35	-	-	-	ISO 4762	-
12	BAUT SEGIENAM	17	-	M6X16	-	-	-	ISO 4162	-
10	T-SLOT M4	16	-	19X8X6,3	-	-	-	-	-
12	T-SLOT M6	15	-	19X8X6,3	-	-	-	-	-
2	BRACKET CORNER 4040	14	-	35X35X28	-	-	-	-	-
3	BRACKET CORNER 8080	13	-	80X80X80	-	-	-	-	-
2	BEARING BLOCK	12	-	64,4X34X23,7	-	-	-	SRF-HGH15	-
2	LINEAR GUIDE RAIL	11	-	440X15X15	-	-	-	SRF-TRH15	-
1	SENSOR INFRARED	10	-	31X15X1,5	-	-	-	MH-B	-
2	SENSOR LOAD CELL 80 kg	9	-	130X28X22	-	-	-	CZL-601	-
1	BRACKET SENSOR INFRARED	8	ABS	31,5X18X11	1,95 g	-	-	DTS-08	A4
1	ADJUSTER SENSOR INFRARED	7	SS400	80X33X14	30,1 g	-	-	DTS-07	A3
1	BRACKET MOTOR	6	SS400	153X64X50	151,3 g	-	-	DTS-06	A3
1	BRACKET SENSOR LOAD CELL	5	SS400	138X61X5	326 g	-	-	DTS-05	A4
2	MANUAL CLAMP	4	6061	32X25X16,5	27,2 g	-	-	DTS-04	A4
1	ALUMUNIUUM PROFILE 8040 - 2	3	6061	250X80X40	0,75 kg	-	-	DTS-03	A4
2	ALUMUNIUUM PROFILE 8040 - 1	2	6061	500X80X40	1,50 kg	-	-	DTS-02	A4
1	ALUMUNIUUM PROFILE 8080	1	6061	400X80X80	1,84 kg	-	-	DTS-01	A4

JML	NAMA BAGIAN	POS	NO.MTL.	UKURAN JADI	BERAT	UKURAN KASAR	NO. ID	F		
>	0	6	30	120	400	1000	PENGGERJAAN LANJUT			
<	6	30	120	400	1000	2000	NO ORDER			
TOL	±0.1	±0.2	±0.3	±0.5	±0.8	±1.2	PROYEKSI			
NAMA							SKALA	DIGAMBAR	15/05/25	RYP
DRONE THRUST STAND							1:5	DIPERIKSA		
NO. ASSY. : -							(1:1)	DISAHKAN		
							(1:2)			
POLITEKNIK MANUFATUR BANDUNG							FORMAT	NO. ID		
(POLITEKNIK MEKANIK SWISS - I T B)							A2	DTS-00		
KOMP. KANAYAKAN, DAGO (JL. IR. H. JUANDA) TROMOL POS 851 BANDUNG 40008 INDONESIA										
TELP. (022) 2500241 FAX. (022) 2502649 EMAIL : polman@meiso.net.id										

DILARANG MEMFOTOKOPI, MEMPERBANYAK, MENYALIN, MEMINDAHKANGANKAN GAMBAR INI TANPA IZIN TERTULIS DARI POLITEKNIK MANUFATUR BANDUNG

DILARANG MEMFOTOKOPI, MEMPERBANYAK, MENYALIN, MEMINDAH TANGKAPAN GAMBAR INI TANPA IZIN TERTULIS DARI POLITEKNIK MANUFAKTUR BANDUNG

	5	4	3	2	1		
NO	PERUBAHAN	TANGGAL	NAMA	NO	PERUBAHAN	TANGGAL	NAMA
-	-	-	-	-	-	-	-

1. ✓
TOL. SEDANG

STANDAR MATERIAL	
MISUMI (LCF8-8080)	

1	-	-	6061	□80X400	1,84 kg	-	-	-
JML	NAMA BAGIAN	POS	NO.MTL.	UKURAN JADI	BERAT	UKURAN KASAR	NO. ID	F
>	0	6	30	120	400	1000	PENERJAAN LANJUT	
<	6	30	120	400	1000	2000		
TOL	±0.1	±0.2	±0.3	±0.5	±0.8	±1.2	-	

NAMA				SKALA		NO ORDER		PROYEKSI	
<h1>ALUMINIUM PROFILE 8080</h1> <h2>DRONE THRUST STAND</h2> <p>NO. ASSY. : DTS-00</p>				1:2		16/05/25		RYP	
						DIGAMBAR		+	
						DIPERIKSA		-	
DISAHKAN		-		-		-			

POLITEKNIK MANUFAKTUR BANDUNG <small>(POLITEKNIK MEKANIK SWISS - I T B) KOMP. KANAYAKAN, DAGO (JL. IR. H. JUANDA) TROMOL POS 851 BANDUNG 40008 INDONESIA TELP. (022) 2500241 FAX. (022) 2502649 EMAIL : polman@melsa.net.id</small>		FORMAT 	NO. ID <h1>DTS-01</h1>
---------------------------------------------------------------------------------------------------------------------------------------------------------------------------------------------------------------------------------------------------------------------------	--	------------	---------------------------

5	4	3	2	1
PENGANTI DARI :-	DIGANTI DENGAN :-	NO. LEMBAR :-	JUMLAH LEMBAR :-	

5		4		3		2		1	
NO	PERUBAHAN	TANGGAL	NAMA	NO	PERUBAHAN	TANGGAL	NAMA		
-	-	-	-	-	-	-	-		



TOL. SEDANG

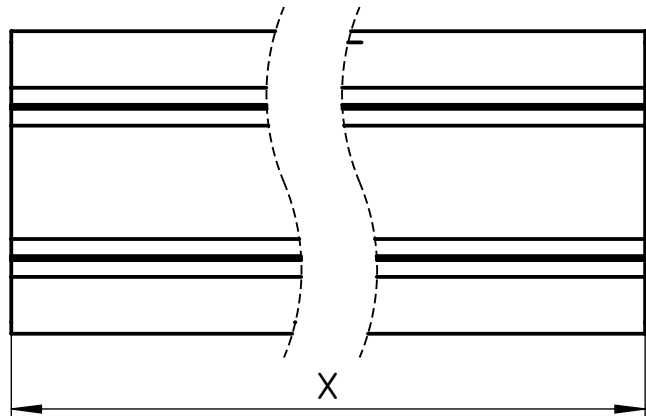
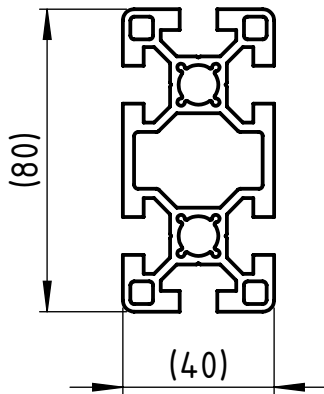

UKURAN X	NO.ID	JUMLAH	STANDAR MATERIAL
500	DTS-02	1	MISUMI (HFS8-4080)
250	DTS-03	1	MISUMI (HFS8-4080)

-	-	-	6061	80x40xX	-	-	-	-				
JML	NAMA BAGIAN					POS	NO.MTL.	UKURAN JADI	BERAT	UKURAN KASAR	NO. ID	F
>	0	6	30	120	400	1000	Pengerjaan Lanjut		NO ORDER		PROYEKSI	
<	6	30	120	400	1000	2000	-		-			
TOL	±0.1	±0.2	±0.3	±0.5	±0.8	±1.2	-		-			

NAMA				SKALA	DIGAMBAR	16/05/25	RYP
ALUMINIUM PROFILE 8040 DRONE THRUST STAND NO. ASSY. : DTS-00				1:2	DIPERIKSA		
					DISAHKAN		



POLITEKNIK MANUFaktur BANDUNG
 (POLITEKNIK MEKANIK SWISS - I T B)
 KOMP. KANAYAKAN, DAGO (JL. IR. H. JUANDA) TROMOL POS 851 BANDUNG 40008 INDONESIA
 TELP. (022) 2500241 FAX. (022) 2502649 EMAIL : polman@melsa.net.id



FORMAT	NO. ID
A4	-

DILARANG MEMFOTOKOPI, MEMPERBANYAK, MENYALIN, MEMINDAHKANGKAN GAMBAR INI TANPA IZIN TERTULIS DARI POLITEKNIK MANUFaktur BANDUNG

5		4		3		2		1	
NO	PERUBAHAN	TANGGAL	NAMA	NO	PERUBAHAN	TANGGAL	NAMA		
-	-	-	-	-	-	-	-		

5. 
TOL. SEDANG

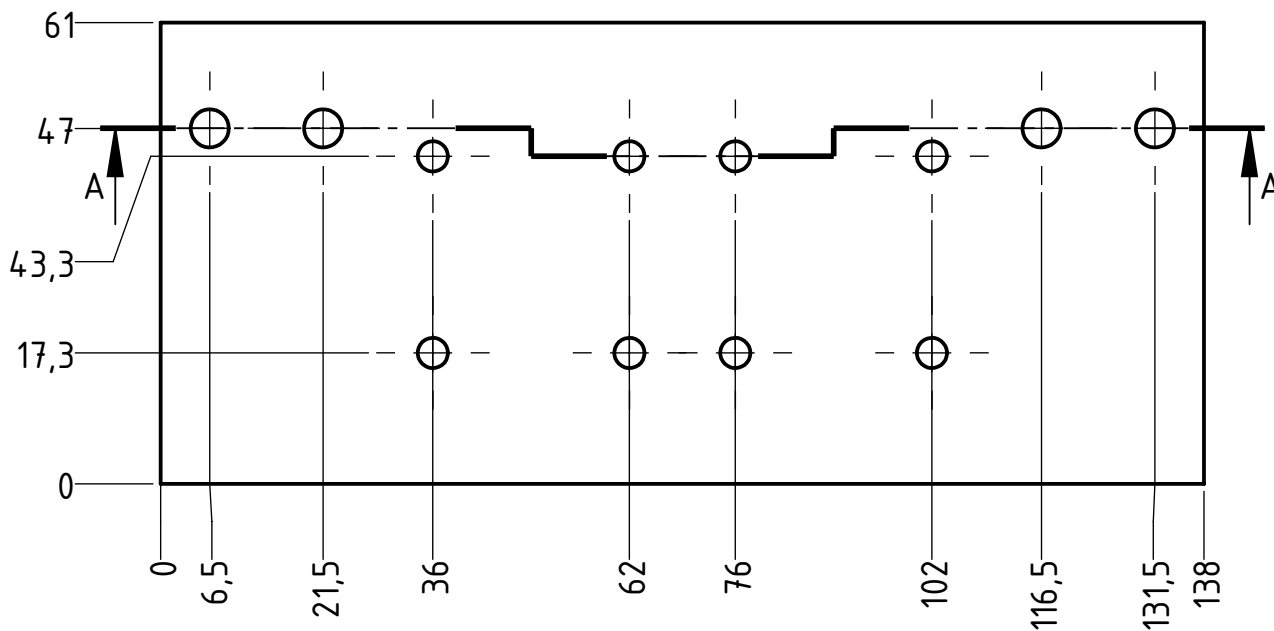
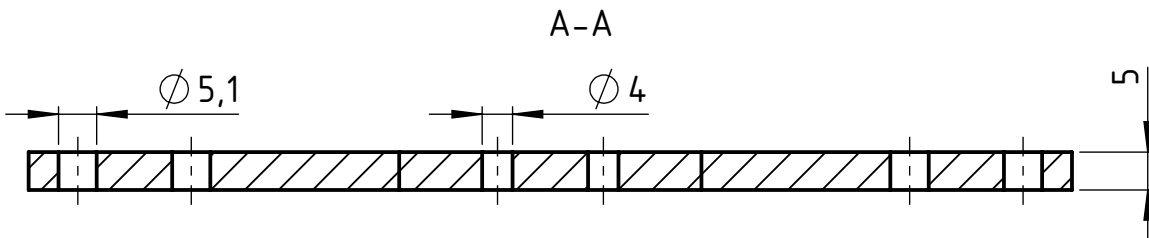

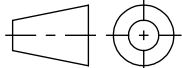
1	-	-	SS400	138X61X5	321 g	-	-	-		
JML	NAMA BAGIAN		POS	NO.MTL.	UKURAN JADI	BERAT	UKURAN KASAR	NO. ID	F	
>	0	6	30	120	400	1000	PENERJAAN LANJUT		NO ORDER	PROYEKSI
<	6	30	120	400	1000	2000	-		-	
TOL	±0.1	±0.2	±0.3	±0.5	±0.8	±1.2	-		-	

NAMA
BRACKET SENSOR LOAD CELL
DRONE THRUST STAND

NO. ASSY. : DTS-00

SKALA 1:1

DIGAMBAR	16/05/25	RYP
DIPERIKSA		
DISAHKAN		



POLITEKNIK MANUFAKTUR BANDUNG
(POLITEKNIK MEKANIK SWISS - I T B)
KOMP. KANAYAKAN, DAGO (JL. IR. H. JUANDA) TROMOL POS 851 BANDUNG 40008 INDONESIA
TELP. (022) 2500241 FAX. (022) 2502649 EMAIL : polman@melsa.net.id

FORMAT
A4

NO. ID
DTS-05

DILARANG MEMFOTOKOPI, MEMPERBANYAK, MENYALIN, MEMINDAHTANGKAN GAMBAR INI TANPA IZIN TERTULIS DARI POLITEKNIK MANUFAKTUR BANDUNG

6. (N10)
TOL. SEDANG

DITEKUK

BENTANGAN

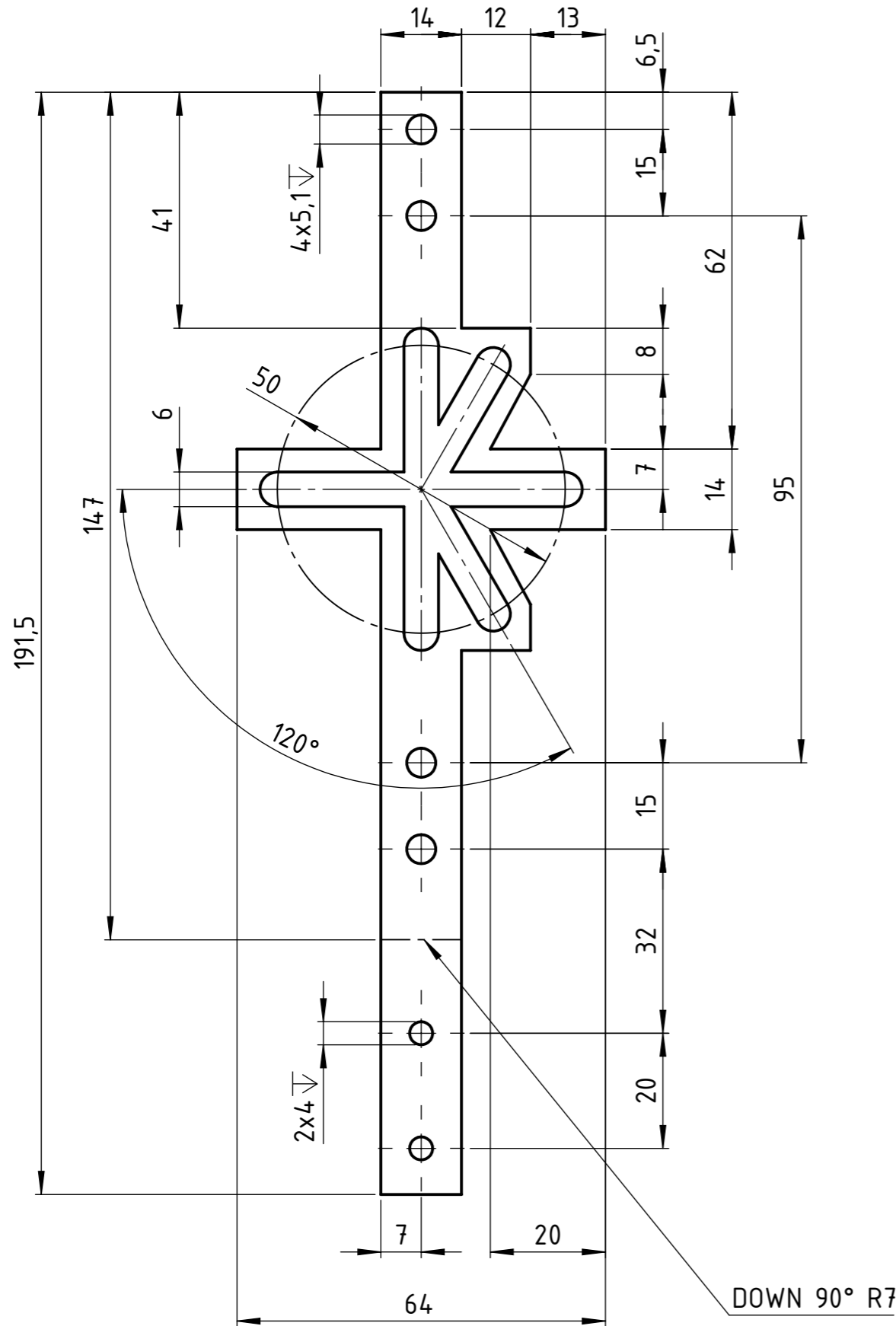

NO	PERUBAHAN	TANGGAL	NAMA	NO	PERUBAHAN	TANGGAL	NAMA
-	-	-	-	-	-	-	-

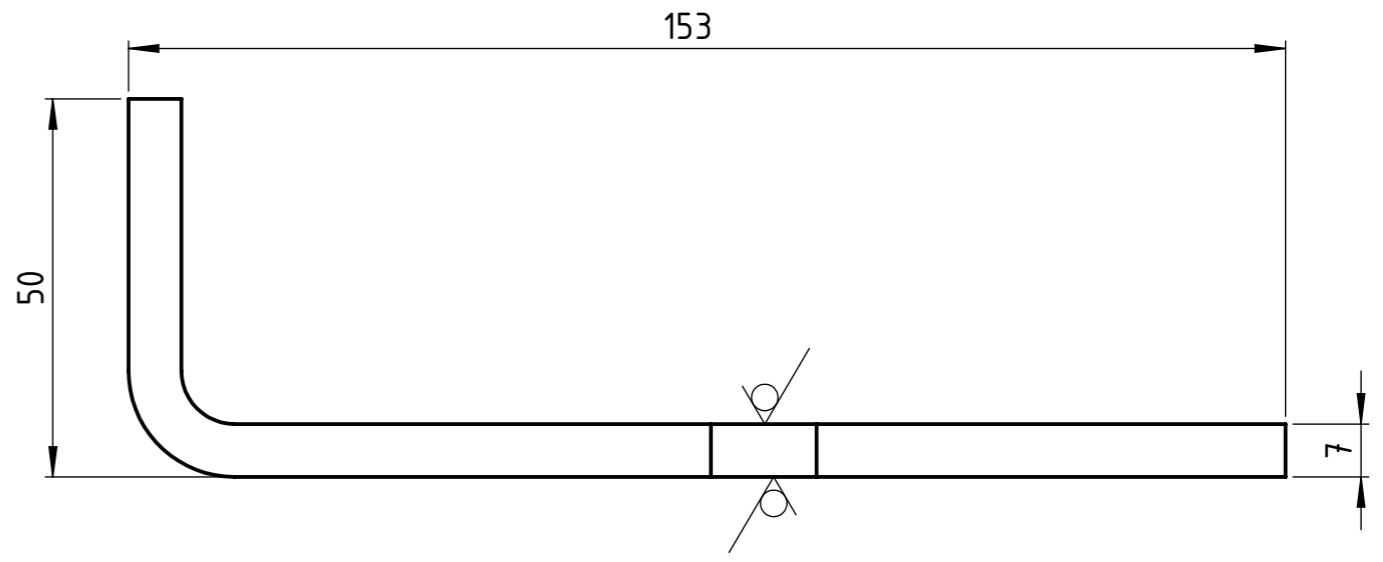
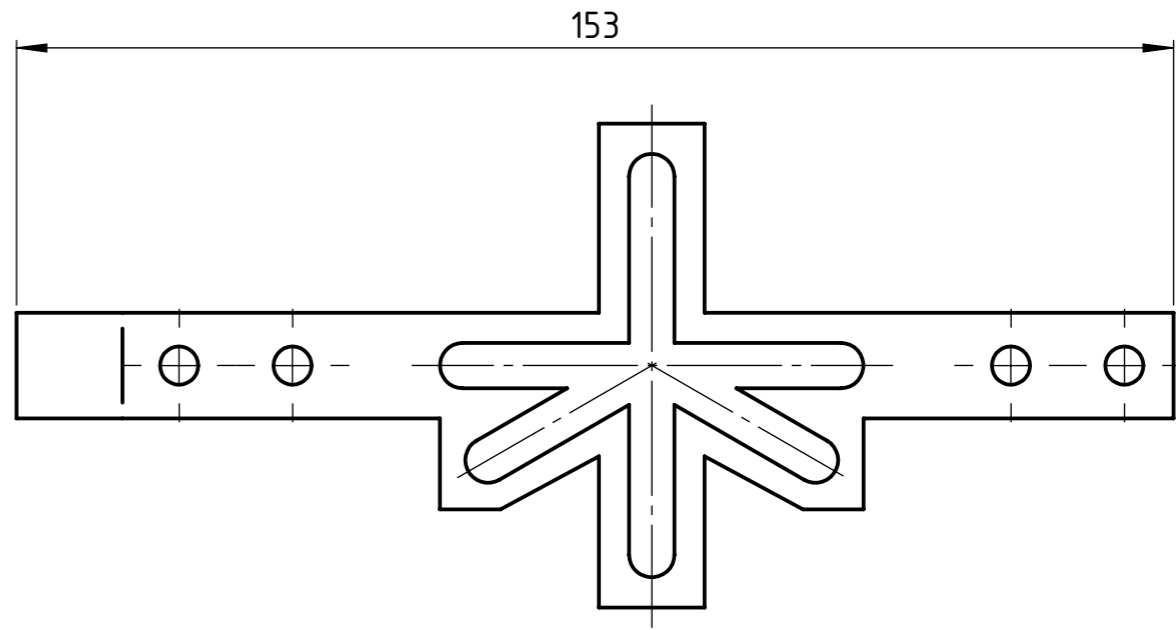

1	-	-	SS400	153X64X50	151,3 g	-	-	-				
JML	NAMA BAGIAN				POS	NO.MTL.	UKURAN JADI	BERAT	UKURAN KASAR	NO. ID	F	
>	0	6	30	120	400	1000	Pengerjaan Lanjut		NO ORDER	PROYEKSI		
<	6	30	120	400	1000	2000	-		-			
TOL	±0.1	±0.2	±0.3	±0.5	±0.8	±1.2	-					
NAMA									SKALA	DIGAMBAR	16/05/25	RYP
BRACKET MOTOR									1:1	DIPERIKSA		
										DRONE THRUST STAND		
NO. ASSY. : DTS-00									FORMAT	NO. ID		
POLITEKNIK MANUFAKTUR BANDUNG <small>(POLITEKNIK MEKANIK SWISS - I T B) KOMP. KANAYAKAN, DAGO (JL. IR. H. JUANDA) TROMOL POS 851 BANDUNG 40008 INDONESIA TELP. (022) 2500241 FAX. (022) 2502649 EMAIL : polman@msls.net.id</small>									A3	DTS-06		

DILARANG MEMFOTOKOPI, MEMPERBANYAK, MENYALIN, MEMINDAHTANGKAN GAMBAR INI TANPA IZIN TERTULIS DARI POLITEKNIK MANUFAKTUR BANDUNG

DILARANG MENFOTOKOPI, MEMPERBANYAK, MENYALIN, MEMINDAHTANGKAN GAMBAR INI TANPA IZIN TERTULIS DARI POLITEKNIK MANUFAKTUR BANDUNG

7. ()

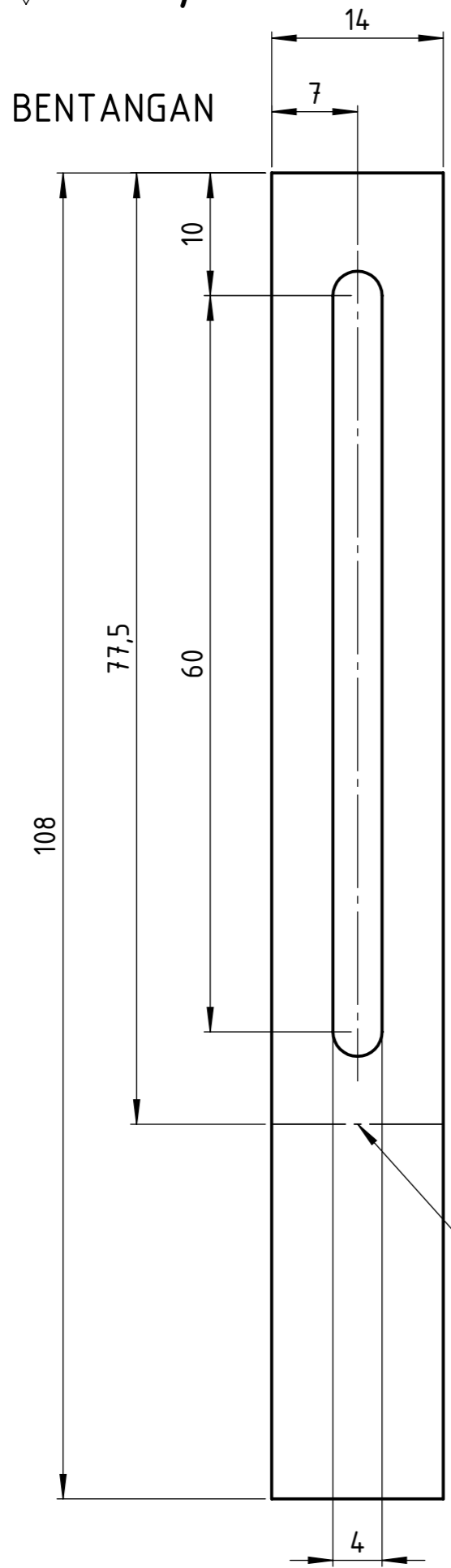

3			2			1		
NO	PERUBAHAN	TANGGAL	NAMA	NO	PERUBAHAN	TANGGAL	NAMA	
-	-	-	-	-	-	-	-	

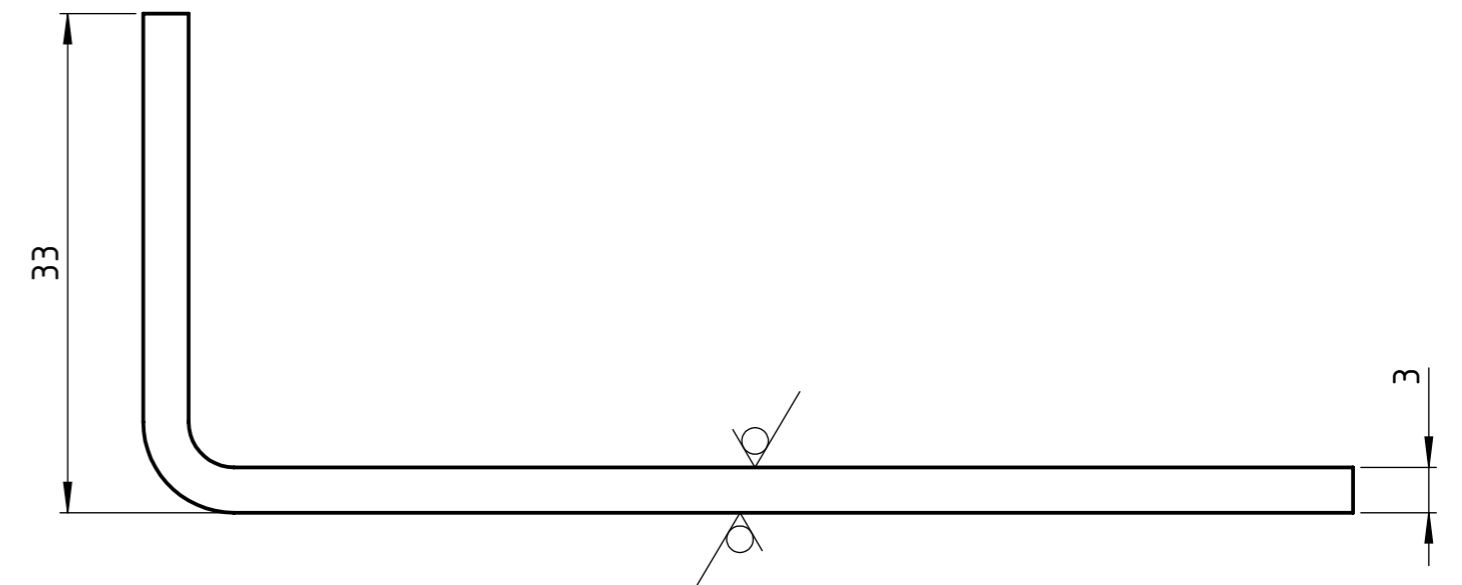
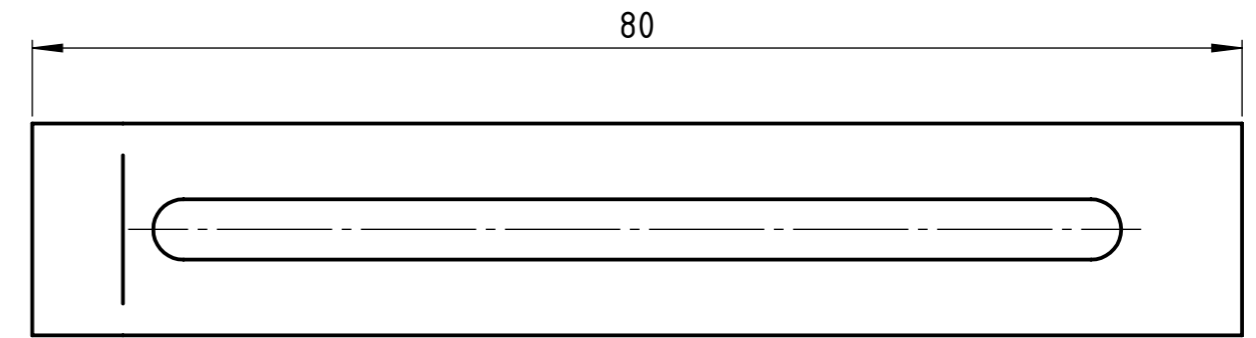

1	-	-	SS400	80X33X14	30,1 g	-	-	-		
JML	NAMA BAGIAN			POS	NO.MTL.	UKURAN JADI	BERAT	UKURAN KASAR	NO. ID	F
>	0	6	30	120	400	1000	PENERJAAN LANJUT	NO ORDER	PROYEKSI	
≤	6	30	120	400	1000	2000			-	-
TOL	±0.1	±0.2	±0.3	±0.5	±0.8	±1.2				
NAMA							SKALA	DIGAMBAR	16/05/25	RYP
ADJUSTER SENSOR INFRARED DRONE THRUST STAND							2:1	DIPERIKSA		
								DISAHKAN		
NO. ASSY. : DTS-00							FORMAT	NO. ID		
POLITEKNIK MANUFAKTUR BANDUNG <small>(POLITEKNIK MEKANIK SWISS - I T B) KOMP. KANAYAKAN, DAGO (JL. IR. H. JUANDA) TROMOL POS 851 BANDUNG 40008 INDONESIA TELP. (022) 2500241 FAX. (022) 2502649 EMAIL : polman@melsa.net.id</small>							A3	DTS-07		

DILARANG MEMFOTOKOPI, MEMPERBANYAK, MENYALIN, MEMINDAHTANGKAN GAMBAR INI TANPA IZIN TERTULIS DARI POLITEKNIK MANUFAKTUR BANDUNG

5		4		3		2		1	
NO	PERUBAHAN	TANGGAL	NAMA	NO	PERUBAHAN	TANGGAL	NAMA		
-	-	-	-	-	-	-	-		

8. DICETAK
TOL. SEDANG

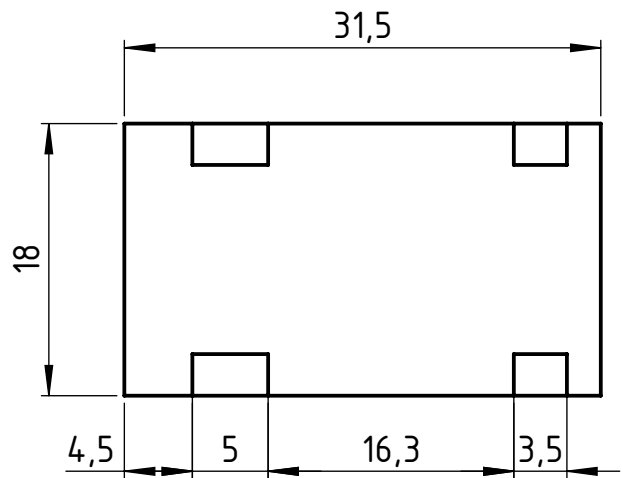
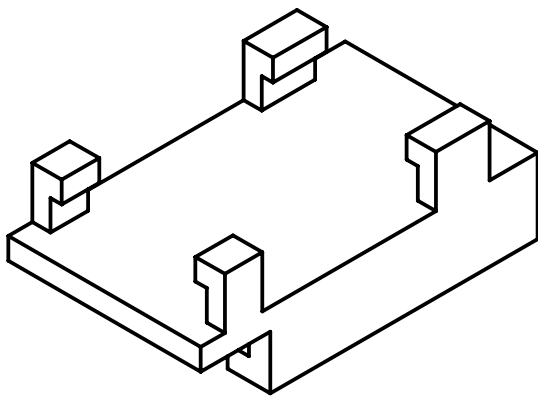
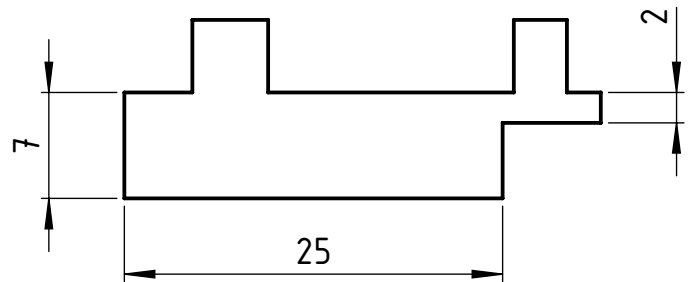
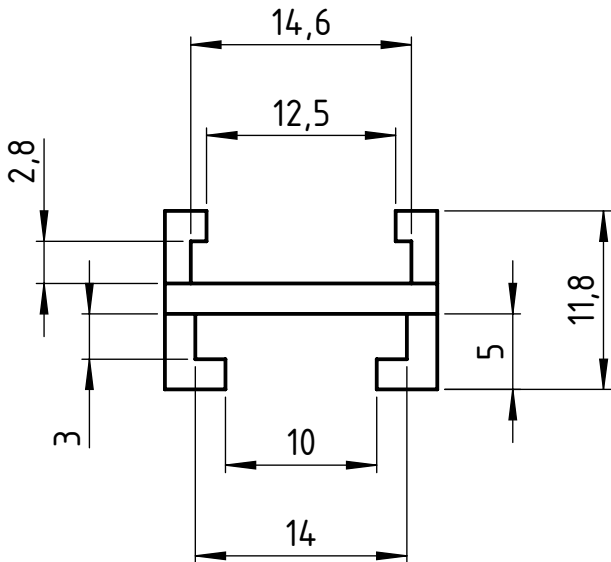

1	-	-	PLA+	31.5X18X11.8	2.05 g	-	-	-	
JML	NAMA BAGIAN		POS	NO.MTL.	UKURAN JADI	BERAT	UKURAN KASAR	NO. ID	F
>	0	6	30	120	400	1000	Pengerjaan Lanjut		
<	6	30	120	400	1000	2000	NO ORDER		
TOL	±0.1	±0.2	±0.3	±0.5	±0.8	±1.2	PROYEKSI		
							-		

NAMA				SKALA	DIGAMBAR	16/05/25	RYP
BRACKET SENSOR INFRARED DRONE THRUST STAND				2:1	DIPERIKSA		
					DISAHKAN		
NO. ASSY. : DTS-00							

POLITEKNIK MANUFAKTUR BANDUNG <small>(POLITEKNIK MEKANIK SWISS - I T B) KOMP. KANAYAKAN, DAGO (JL. IR. H. JUANDA) TROMOL POS 851 BANDUNG 40008 INDONESIA TELP. (022) 2500241 FAX. (022) 2502649 EMAIL : polman@melsa.net.id</small>				FORMAT	NO. ID
					DTS-08